



US006970580B2

(12) **United States Patent**
Kies

(10) **Patent No.:** **US 6,970,580 B2**
(45) **Date of Patent:** **Nov. 29, 2005**

(54) **SYSTEM AND METHOD FOR MAINTAINING A VIDEO IMAGE IN A WIRELESS COMMUNICATION DEVICE**

(75) Inventor: **Jonathan K. Kies**, Encinitas, CA (US)

(73) Assignee: **Qualcomm Incorporated**, San Diego, CA (US)

(*) Notice: Subject to any disclaimer, the term of this patent is extended or adjusted under 35 U.S.C. 154(b) by 507 days.

(21) Appl. No.: **10/099,844**

(22) Filed: **Mar. 13, 2002**

(65) **Prior Publication Data**

US 2003/0072474 A1 Apr. 17, 2003

Related U.S. Application Data

(60) Provisional application No. 60/348,113, filed on Oct. 17, 2001.

(51) **Int. Cl.**⁷ **G06K 9/00**; H04N 7/14; H04N 7/20

(52) **U.S. Cl.** **382/118**; 348/14.02; 455/422.1

(58) **Field of Search** 382/118, 165, 181, 382/274, 295, 312; 455/73, 3.01, 403, 422.1; 348/515, 14.02

(56) **References Cited**

U.S. PATENT DOCUMENTS

6,177,950 B1 * 1/2001 Robb 348/14.01
6,310,609 B1 * 10/2001 Morgenthaler 345/170
6,459,882 B1 * 10/2002 Palermo et al. 455/41.1

FOREIGN PATENT DOCUMENTS

EP 0550172 7/1993
EP 0756426 1/1997
EP 0884905 12/1998

* cited by examiner

Primary Examiner—Kanjibhai Patel

(74) *Attorney, Agent, or Firm*—Philip Wadsworth; Charles D. Brown; Howard H. Seo

(57) **ABSTRACT**

A wireless communication device (100) may include a video-input device (118), a signaling device (128), video-conferencing capabilities and other features. An image-recognition processor (126) selectively generates feedback signals based on characteristics of a face in an image received by the video-input device (118). In one embodiment, these feedback signals are used to selectively control the signaling device (128) to communicate to a user characteristics of the face in the image received by the video-input device (118), so that the user may take appropriate action if desired.

13 Claims, 4 Drawing Sheets

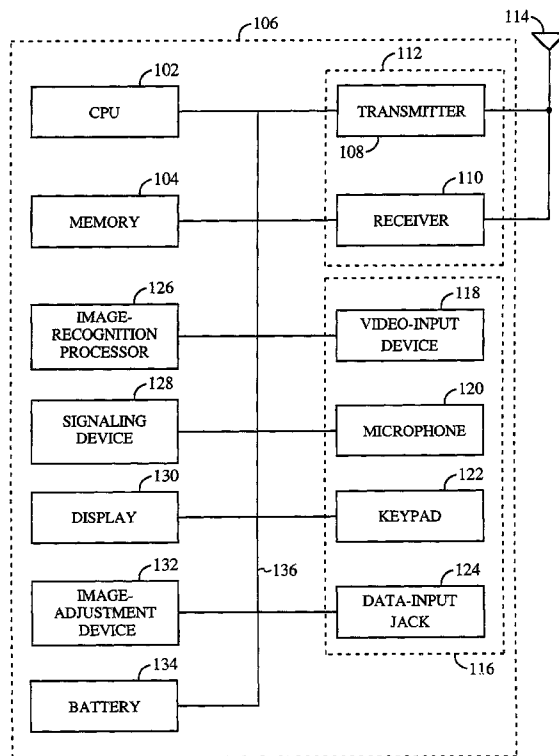

SYSTEM 100

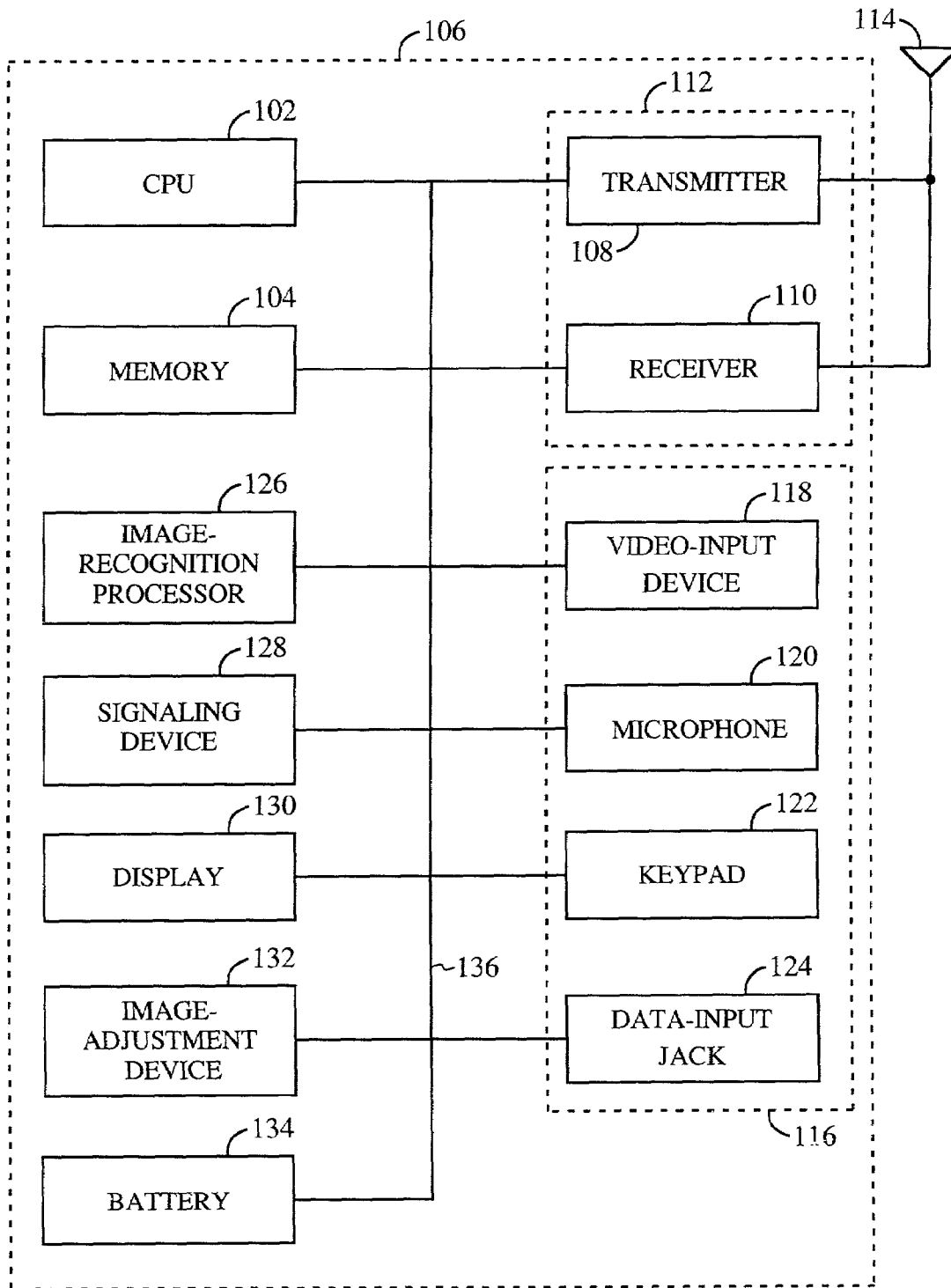

SYSTEM 100

FIG. 1

EXAMPLES OF FACES RECEIVED BY
THE SYSTEM 100

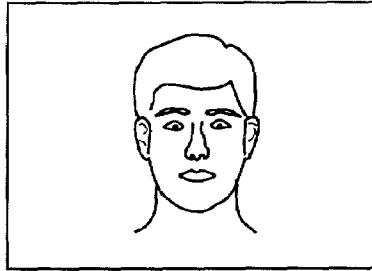

FACE WITHIN
TOLERANCES

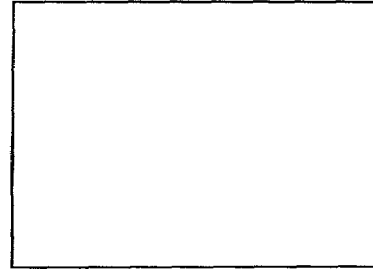

NO FACE



FACE OFF CENTER

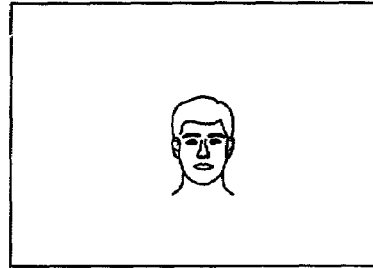

FACE TOO SMALL

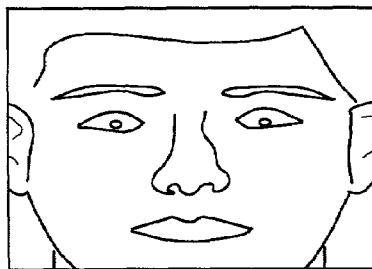

FACE TOO BIG

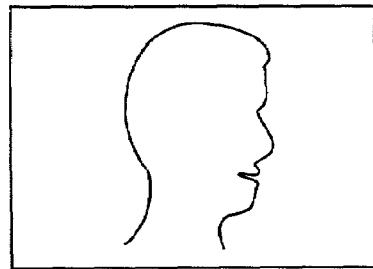

IMPROPERLY-ORIENTED
FACE

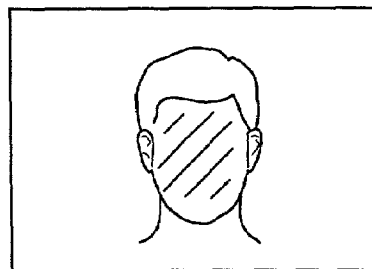

FACE TOO DARK

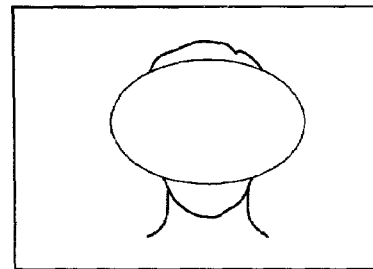

GLARE ON THE FACE

FIG. 2

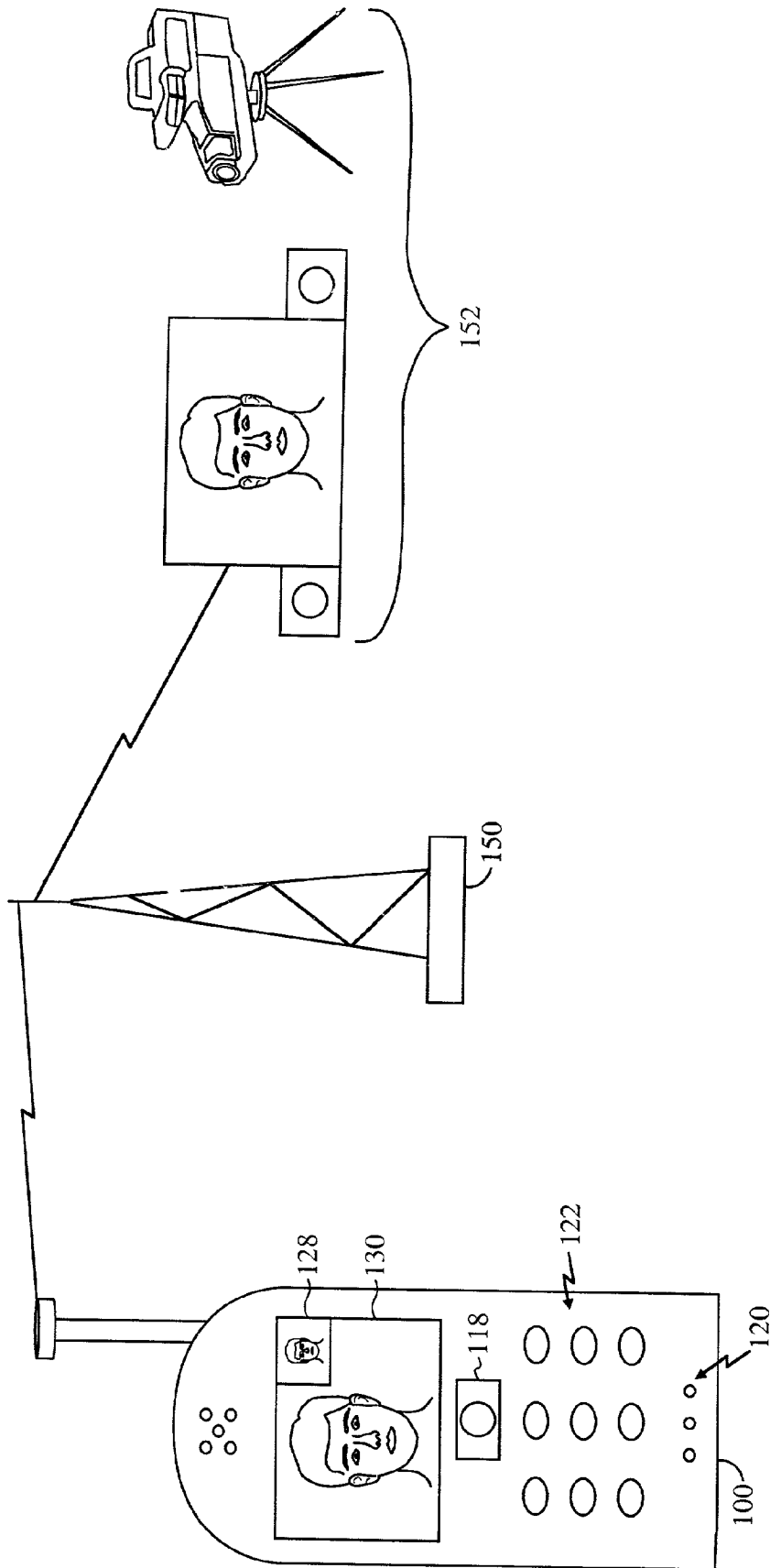

FIG. 3

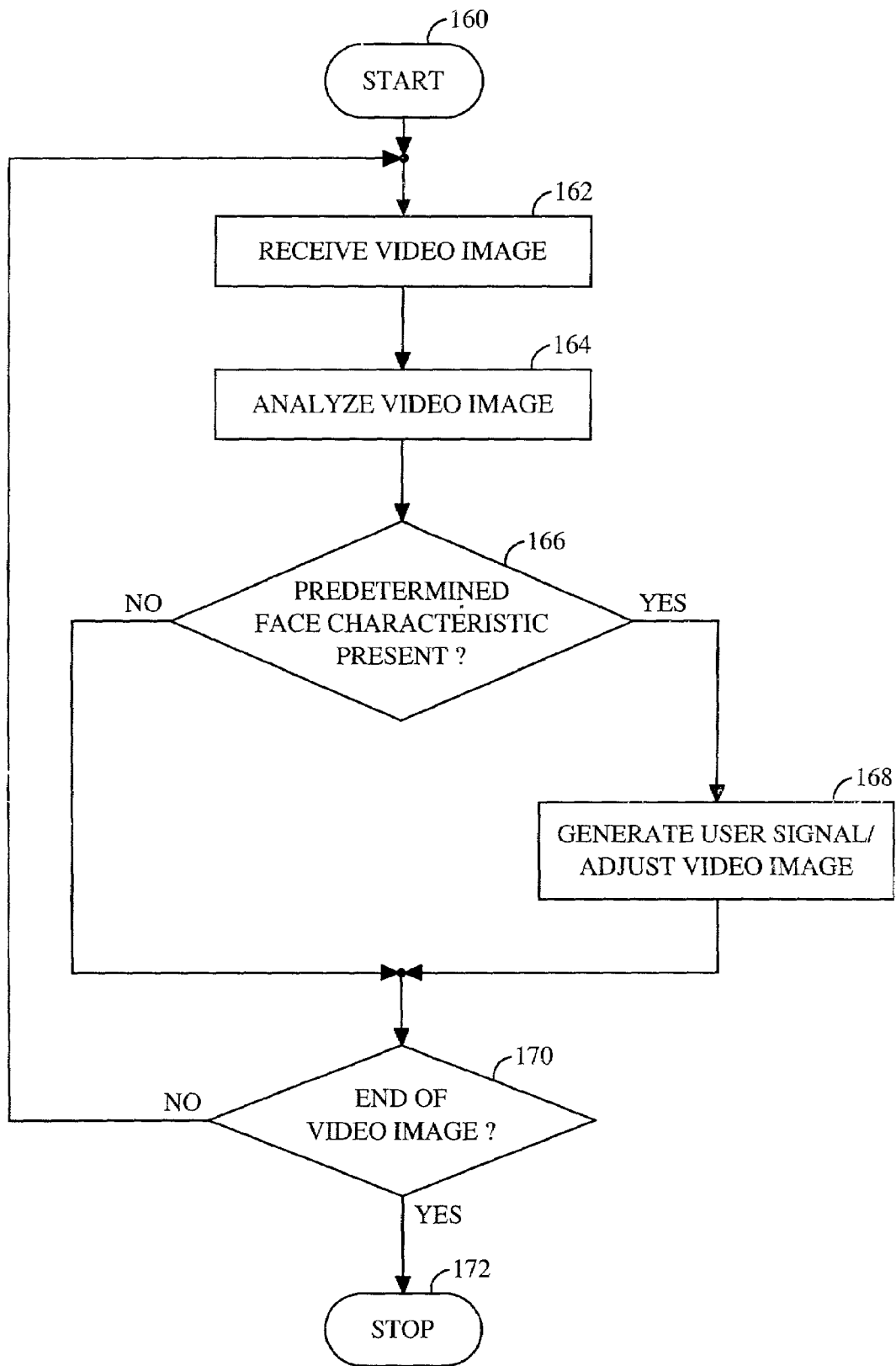

FIG. 4

SYSTEM AND METHOD FOR MAINTAINING A VIDEO IMAGE IN A WIRELESS COMMUNICATION DEVICE

RELATED APPLICATIONS

This application claims priority from U.S. Provisional Application Ser. No. 60/348,113, filed Oct. 17, 2001, the content of which is incorporated herein by reference in its entirety.

BACKGROUND OF THE INVENTION

Field of Invention

The present invention is directed generally to a wireless communication device, and, more particularly, to a system and method for maintaining a video image in a wireless communication device.

Wireless communications devices, such as cellular telephones, typically include a housing and various data input and output devices, such as a keyboard, a display, a microphone and a speaker. In addition, some wireless communications devices have video conferencing capabilities.

The mobile nature of a wireless communication device and the small display increase the probability that a video conferencing user will transmit a video image that is too dark, too bright, too close, too far, improperly centered, or improperly oriented in the video-image frame. Therefore, it can be appreciated that there is a significant need for a system and method of maintaining proper a video image, either by signaling the need for action to the user or by automatically adjusting the wireless communication device, or some combination thereof. The present invention provides this and other advantages, as will be apparent from the following detailed description and accompanying figures.

SUMMARY OF THE INVENTION

The present invention is embodied in a system and method for recognizing characteristics in a video image in a wireless communications device. In one embodiment the system includes a housing, a transceiver, a display capable of displaying video images, a signaling device such as a ringer or a speaker, and a video-input device, such as a camera or lens. The system also includes an image-recognition processor. The image-recognition processor can be configured to generate feedback based on characteristics of the video image received by the video-input device. The user or the communications device can then use this information to maintain or adjust the video image received by the video-input device.

BRIEF DESCRIPTION OF THE DRAWINGS

FIG. 1 is a functional block diagram of a wireless communication device implementing the present invention.

FIG. 2 illustrates examples of characteristics of a face in an image received by the system of FIG. 1.

FIG. 3 illustrates the operation of the system of FIG. 1 to transmit a video image to a remote location.

FIG. 4 is a flowchart illustrating the operation of the system of FIG. 1 to signal to the user a suggested course of action to adjust a video image or, alternatively, to automatically adjust the video image.

DETAILED DESCRIPTION OF THE PREFERRED EMBODIMENTS

The present invention provides feedback on a video image received by a video-input device of a wireless communications device, and as a result enables a user or the wireless communications device to take appropriate action to maintain or adjust characteristics of the video image. The present invention may be readily implemented in any wireless communication device. Although the examples presented herein refer to a cellular phone, the principles of the present invention are applicable to any wireless communication device, including, but not limited to, analog and digital cellular telephones, personal communications system (PCS) devices, and the like. The present invention is embodied in a system **100** illustrated in the functional block of FIG. 1. The system **100** includes a central processing unit (CPU) **102**, which controls operation of the system. A memory **104**, which may include both read-only memory (ROM) and random-access memories (RAM), provides instructions and data to the CPU **102**. A portion of the memory **104** may also include non-volatile random-access memory.

The system **100**, which is typically embodied in a wireless communication device such as a cellular telephone, also includes a housing **106** that contains a transmitter **108** and a receiver **110** to allow transmission and reception of data, such as audio and video communications and programming data, between the system **100** and a remote location, such as a base transceiver station (BTS) **150** (see FIG. 3), a remote video-conferencing center **152** (see FIG. 3), another system **100**, or the like. The transmitter **108** and the receiver **110** may be combined into a transceiver **112**. An antenna **114** is attached to the housing **106** and electrically coupled to the transceiver **112**. The operation of the transmitter **108**, receiver **110**, and antenna **114** is well-known in the art and need not be described herein. Although FIG. 1 illustrates the antenna **114** as extending from the housing **106**, some designs may include an internal antenna that is contained completely within the housing. The transmitter **108**, the receiver **110**, and the antenna **114**, however, operate in a conventional manner regardless of the location of the antenna.

A user-input device **116**, comprising at least a video-input device **118**, is communicatively linked to the system **100** for operation by the user in a conventional manner. The user-input device **116** provides a convenient means by which destination telephone numbers, commands, video images, voice data and other data may be entered by the user. Although FIG. 1 illustrates the user-input device **116** as comprising a video-input device **118**, a microphone **120**, a keypad **122**, and a data-input jack **124** contained within the housing **106**, other user input devices may be used, such as the receiver, and the like, and in various combinations. In addition, while the video-input device **118** may be a camera (see FIG. 3), one skilled in the art will recognize that other video-input devices **118** may be used, including the data-input jack **124**, the receiver **110**, and the like, and in various combinations.

The system **100** also includes an image-recognition processor **126**, which may typically be included in the CPU **102**. As will be discussed in greater detail below, system **100** may use the image-recognition processor **126** to generate feedback signals based on selected characteristics of a face in a video image received by the video-input device **118**. The image-recognition processor **126** uses pattern-recognition methods which are known in the prior art to recognize selected characteristics of a face in a video-image received

by the video-input device **118**, such as the lighting, location, size and orientation of the face in the video image. Pattern-recognition methods are not the subject of this invention and will not be discussed in detail herein.

The image-recognition processor **126** compares characteristics of the face in the video image received by the video-input device **118**, such as the lighting, location, size, or orientation of the face, to a predetermined set of undesirable face-characteristics, such as characteristics indicating the face is improperly lighted, located, sized, or oriented. The predetermined set of face characteristics may be stored, by way of example, in the memory **104**. If the correlation between the characteristics of the face in the video image received by the video input device **118** and one of the predetermined face-characteristics exceeds a threshold value, the image-recognition processor **126** determines that the face in the video image received by the video-input device **118** possesses the predetermined face-characteristic. One skilled in the art will recognize that the image-recognition processor **126** may also rely on other data to determine whether a face in the video image possesses a predetermined face-characteristic, such as user-entered data or data received from a light-sensor (not shown) or a Doppler-ranging system (not shown), or the like, and in various combinations.

The image-recognition processor **126** may be readily implemented as a series of software instructions placed in the memory **104** and executed by the CPU **102**. Thus, minor software modifications to existing hardware will allow the implementation of the system **100**.

In one embodiment, the system **100** also includes a signaling device **128**, to signal the user if one of the predetermined face-characteristics are present in the face in the video-image received by the video-input device. One skilled in the art will recognize that a signaling device **128** may be a ringer, a buzzer, a vibrator, a flashing light, a speaker, a display **130**, and the like, and various combinations thereof. As will be discussed in more detail below, the image-recognition processor **126** may generate control signals based on the presence of one or more predetermined face-characteristics in the video image received by the video-input device to selectively operate the signaling device **128**.

In another embodiment, the system **100** also includes an image-adjustment device **132** to adjust the video image received by the video-input device **118**, which may or may not be incorporated into the video-input device **118**. One skilled in the art will recognize that the image-adjustment device **132** may be a light, a focusing lens, a horizontal or vertical frame adjustment mechanism, and the like and various combinations thereof. As will be discussed in more detail below, the image-recognition processor **126** may automatically generate control signals based on the presence of one or more predetermined face-characteristics in the video image received by the video-input device **118** to selectively control the image-adjustment device **132**.

Electrical components of the system **100** receive power from a battery **134**, which is attached to and supported by the housing **106**. In an exemplary embodiment, the battery **134** is a rechargeable battery. In other embodiments, the system **100** may include a connector (not shown) for the connection of an external power source, such as an automobile power adapter, AC power adapter, or the like.

The various components of the system **100** are coupled together by a bus system **136** which may include a power bus, control bus, and status signal bus in addition to a data

bus. For the sake of clarity, however, the various buses are illustrated in FIG. **1** as the bus system **136**.

FIG. **2** illustrates some desirable and undesirable characteristics that may be present in a face in a video image received by the system **100**. For example, the face may be within tolerances, there may be no face present in the image, the face may be off-center, the face may be too small or too big, the face may be improperly-oriented, the face may be too dark, or there may be glare on the face. One skilled in the art will recognize that a video image received by a wireless communications device may have a variety of characteristics, and in various combinations, which can be maintained or adjusted by the user or by automatically adjusting the wireless communication device, or by some combination thereof.

FIG. **3** illustrates the operation of the system **100** to transmit the video image to a remote location, such as a BTS **150** or a remote video conferencing center **152**. One skilled in the art will recognize that the video image may be transmitted to a variety of remote locations, such as another system **100**, or the like. For the sake of brevity, the system **100** will be described using a limited number of examples.

In one embodiment, the system **100** is configured to receive and analyze a face in a video image received by the video input device **118** (see FIG. **1**) and alert the user if one of a set of predetermined face-characteristics is present in the face in the video image so that the user may take action if desired. In this embodiment, the image-recognition processor **126** is configured to compare characteristics of a face in a video image to a predetermined set of face-characteristics and selectively generate a feed-back signal based on the comparison.

The user may provide an image, which has one of a set of predetermined face-characteristics, to the video-input device **118**. For example, the user may provide the video-input device **118** with an image of a face which is too small. The image-recognition processor **126** receives the video image from the video-input device **118**. The image-recognition processor **126** analyzes characteristics of the face in the video image, such as the size of the face. The image-recognition processor **126** compares the characteristics of the face in the video image to a predetermined set of face-characteristics. In this example, the image-recognition processor **126** determines that the characteristics of the face in the video image match the characteristics of a face which is too small. Based on the comparison, the image-recognition processor **126** selectively generates a feedback signal corresponding to the presence of one of the set of face-characteristic in the face in the video image.

The signaling device **128** receives the selectively-generated feed-back signal from the image-recognition processor **126**. The signaling device **128** selectively generates a user-signal to indicate to the user that one of the predetermined face-characteristics is present in the video image. For example, the signaling device **128** may make a noise, vibrate, flash a light, or display an error message or a video image. In response to the user-signal, the user may take action to maintain or adjust the video image, in this example, the user may move closer to the video-input device **118**.

In another embodiment, the system **100** is also configured to convey information to the user related to the comparison of the face in the video image to the predetermined set of face characteristics. In this embodiment, the selectively generated feedback signal is one of a set of predetermined feedback signals corresponding to the set of predetermined face-characteristics and the user-signal is one of a set of

5

predetermined user-signals corresponding to the predetermined set of feedback signals.

For example, the user may provide an image of a face which is improperly positioned to the video input device **118** and thus cuts off a portion of the face. The image-recognition processor **126** receives the video image from the video-input device **118**. The image-recognition processor **126** analyzes the characteristics of the face in the video image, such as the location of the face. The image-recognition processor **126** compares the characteristics of the face in the video image to a predetermined set of face-characteristics. In this example, the image-recognition processor **126** determines that the characteristics of the face in the video image match the characteristics of a face, which is improperly positioned. Based on the comparison, the image-recognition processor **126** selectively generates one of a predetermined set of feedback signals, in this example a feedback signal corresponding to a face in the video image which is improperly positioned.

The signaling device **128** receives the selectively-generated feed-back signal from the image-recognition processor **126**. The signaling device **128** selectively generates a user-signal corresponding to the selectively generated feedback signal. For example, the signaling device **128** selectively generates a user-signal corresponding to the feedback signal corresponding to a face in the video image which is positioned too low. One skilled in the art will recognize that the signaling device **128** may signal the presence of one of the predetermined set of face-characteristics in various manners and combinations thereof. In this example, for instance, the signaling device **128** may make a noise indicating that the image is off-center, may state or flash the message "image too low", or the like, or may show a picture or a video image on the display **130**, or in a portion of the display **130**, indicating that the face in the image is too low, or the like, and in various combinations. In this example, the user may respond to the user-signal by adjusting the video-input device **118** or repositioning themselves, or some combination thereof, so that the face in the image received by the video-input device **118** is raised.

In another embodiment the system **100** is configured to receive and analyze a face in a video image received by the system **100** and automatically adjust the video image if one of a set of predetermined face-characteristics is present in the face in the video image. In this embodiment, the image-recognition processor **126** is configured to compare characteristics of a face in the video image to a predetermined set of face-characteristics and selectively generate one of a set of predetermined feedback signals based on the comparison. The image-adjustment device **132** is configured to adjust the image received by the video-input device **118**, wherein the adjustment is based at least in part on the selectively-generated feedback signal.

For example, image of a face received by the video-input device **118** may be too dark. The image-recognition processor **126** receives the video-image from the video-input device **118**. The image-recognition processor **126** analyzes characteristics of the face in the video-image, such as the lighting on the face. The image-recognition processor **126** compares the characteristics of the face in the video image to a predetermined set of face-characteristics. In this example, the image-recognition processor **126** determines that the characteristics of the face in the video image match the characteristics of a face that is too dark. Based on the comparison, the image-recognition processor **126** selectively generates one of a set of predetermined feedback

6

signals, in this example a feedback signal corresponding to a face in the video image that is too dark.

The image-adjustment device **132** receives the selectively generated feedback signal from the image-recognition processor **126** and adjusts the image received by the video-input device **118** based, at least in part, on the selectively generated feedback signal. In this example, the image-adjustment device **132** may be a light which is activated in response to the selectively-generated feedback signal to adjust the brightness of the image received by the video-input device **118**, an automatically adjustable lens of the video-input device **118**, an electrical gain adjustment to boost the brightness of the video signal, or the like.

Those skilled in the art will recognize that the video-images, face-characteristics, feedback signals, user-signals, and adjustments used above are illustrative only and that the present invention is not limited to the specific video-images, face-characteristics, feedback signals, user-signals and adjustments mentioned.

The operation of the system **100** to signal to the user a suggested course of action to adjust a video image received by the video-input device **118** is illustrated by FIG. 4. At a start **160**, the wireless communications device is under power. At step **162**, the system receives a video image from the video-input device **118**. At step **164**, the image-recognition processor **126** analyzes the video image, recognizes characteristics of a face in the video image and compares the characteristics of the face in the video image to a predetermined set of face-characteristics. At decision **166**, the system **100** determines whether one of the predetermined set of face characteristics is present in the face in the video image.

If one of the predetermined face-characteristics is present, the result of decision **166** is YES. In that event the system **100** generates a predetermined user-signal corresponding to the predetermined face-characteristic in step **168**. The user may take action in response to the user-signal, such as adjusting the video-input device. Alternatively, the system **100** may automatically adjust the video image received by the system **100** in step **168**, wherein the adjustment is based at least in part on the predetermined face characteristic. Those skilled in the art will recognize that the system **100** may generate a user-signal or adjust the video image, or some combination thereof, in step **168**. The system **100** then proceeds to decision **170**.

If none of the predetermined face-characteristics are present, the result of decision **166** is NO. In that event the system **100** proceeds to decision **170**.

At decision **170**, the system **100** determines whether it is still receiving a video image. If the video-input device **118** is still receiving a video image, the result of decision **170** is YES. In that event, the system **100** returns to step **162** to receive additional video images. If the video input device is no longer receiving a video image, the result of decision **170** is NO. In that event the system **100** ends the operation in step **172**.

Those skilled in the art will recognize that additional steps, such as error checking routines and transmission of the video-image received by the system **100**, and the like, may be performed. For the sake of brevity, those flowcharts will not be repeated herein. However, one of ordinary skill in the art may readily implement such processes based on the present disclosure.

It is to be understood that even though various embodiments and advantages of the present invention have been set forth in the foregoing description, the above disclosure is illustrative only, and changes may be made in detail, yet remain within the broad principles of the invention. For

7

example, the set of predetermined face characteristics are described above as a set of undesirable characteristics. However, the system **100** may be readily implemented using a set of predetermined desirable face characteristics. The image-recognition processor **126** (see FIG. **1**) can generate the selectively-generated feedback signals when the image is altered in an unacceptable manner. Therefore, the present invention is to be limited only by the appended claims.

What is claimed is:

1. A system to provide feedback on a face in a video image received by a wireless communication device, the system comprising:

- a video-input device to receive the video image;
- an image-recognition processor coupled to the video-input device to receive and analyze the video image, wherein the image-recognition processor is configured to recognize characteristics of the face in the received video image, compare the characteristics of the face in the received video image to a predetermined set of face-characteristics and selectively generate a feedback signal based on the comparison;
- a signaling device to receive the selectively-generated feedback signal and selectively generate a user-signal based at least in part on the feedback signal received from the image-recognition processor; and
- a transmitter to transmit the received video image to a remote location.

2. The system of claim **1** wherein the selectively-generated feedback signal is one of a predetermined set of feedback signals to convey information related to the comparison of the characteristics of the face in the received video image to the predetermined set of face-characteristics and the user-signal is one of a predetermined set of user-signals to convey information to the user related to the comparison of the face in the received video image to the predetermined set of face-characteristics.

3. The system of claim **1** wherein the selectively-generated user-signal comprises an audio signal.

4. The system of claim **1** wherein the selectively-generated user-signal comprises a visual signal.

5. The system of claim **4** wherein the selectively-generated user-signal comprises a video signal.

6. A system to provide feedback on a face in a video image received by a wireless communication device, the system comprising:

- a video-input device to receive the video image;
- an image-recognition processor coupled to the video-input device to receive and analyze the video image, wherein the image-recognition processor is configured to recognize characteristics of the face in the received video image, compare the characteristics of the face in the received video image to a predetermined set of

8

face-characteristics and selectively generate a feedback signal based on the comparison;

an image-adjustment device to adjust the image received by the video-input device, wherein the adjustment is based at least in part on the selectively-generated feedback signal; and

a transmitter to transmit the received video image to a remote location.

7. The system of claim **6** wherein the selectively-generated feedback signal is one of a set of predetermined feedback signals.

8. A method to provide feedback on a face in a video image received by a wireless communication device, the method comprising:

- receiving the video image;
- comparing characteristics of the face in the received video image to a predetermined set of face-characteristics and selectively generating a feedback signal on the comparison;
- selectively generating a user-signal based at least in part on the comparison of the face in the received video image to the predetermined set of face-characteristics; and
- transmitting the received video image to a remote location.

9. The method of claim **8** wherein the selectively-generated user-signal is one of a predetermined set of user-signals to convey information to the user related to the comparison of the face in the received video image to the predetermined set of face-characteristics.

10. The method of claim **8** wherein the selectively-generated user-signal comprises an audio signal.

11. The method of claim **8** wherein the selectively-generated user-signal comprises a visual signal.

12. The method of claim **11** wherein the selectively-generated user-signal comprises a video signal.

13. A method to provide feedback on a face in a video image received by a wireless communication device, the method comprising:

- receiving the video image;
- comparing characteristics of the face in the received video image to a predetermined set of face-characteristics and selectively generating a feedback signal based on the comparison;
- automatically adjusting the wireless communications device based at least in part on the comparison of the characteristics of the face in the received video image to the predetermined set of face characteristics; and
- transmitting the received video image to a remote location.

* * * * *