

(12) **United States Patent**  
**Laroia et al.**

(10) **Patent No.:** **US 7,295,509 B2**  
(45) **Date of Patent:** **Nov. 13, 2007**

- (54) **SIGNALING METHOD IN AN OFDM MULTIPLE ACCESS SYSTEM**
- (75) Inventors: **Rajiv Laroia**, Basking Ridge, NJ (US);  
**Junyi Li**, Pine Brook, NJ (US);  
**Sathyadev Venkata Uppala**, Scotch Plains, NJ (US)
- (73) Assignee: **QUALCOMM, Incorporated**, San Diego, CA (US)

5,406,551 A *	4/1995	Saito et al.	370/203
5,410,538 A	4/1995	Roche et al.	
5,491,727 A *	2/1996	Petit	375/270
5,548,582 A	8/1996	Brajal et al.	
5,612,978 A	3/1997	Blanchard et al.	
5,822,368 A	10/1998	Wang	
5,838,268 A *	11/1998	Frenkel	341/111
5,955,992 A *	9/1999	Shattil	342/375
6,175,550 B1 *	1/2001	van Nee	370/206

(Continued)

**FOREIGN PATENT DOCUMENTS**

EP 0 786 889 A1 7/1997

(Continued)

**OTHER PUBLICATIONS**

Carl R. Nassar, Introduction of carrier interference to spread spectrum multiple access, Apr. 1999, IEEE, pp. 1-5.\*  
Shattil, Steven; Multiple access method and system, Aug. 1999, PCT, pp. 1-25.\*

(Continued)

*Primary Examiner*—Steven Nguyen

(74) *Attorney, Agent, or Firm*—Straub & Pokotylo; Michael P. Straub

(\* ) Notice: Subject to any disclaimer, the term of this patent is extended or adjusted under 35 U.S.C. 154(b) by 842 days.

(21) Appl. No.: **09/805,887**

(22) Filed: **Mar. 15, 2001**

(65) **Prior Publication Data**

US 2002/0172213 A1 Nov. 21, 2002

**Related U.S. Application Data**

(60) Provisional application No. 60/230,937, filed on Sep. 13, 2000.

(51) **Int. Cl.**

**H04J 11/00** (2006.01)  
**H04B 7/216** (2006.01)  
**H04J 7/00** (2006.01)  
**H04B 1/00** (2006.01)

(52) **U.S. Cl.** ..... **370/208; 370/213; 370/342; 375/130**

(58) **Field of Classification Search** ..... **370/203–210; 375/260–261, 270, 296, 298, 301, 346, 348**  
See application file for complete search history.

(56) **References Cited**

**U.S. PATENT DOCUMENTS**

5,282,222 A 1/1994 Fattouche et al.

(57)

**ABSTRACT**

A method for reducing the peak-to-average ratio in an OFDM communication signal is provided. The method includes defining a constellation having a plurality of symbols, defining a symbol duration for the OFDM communication signal, and defining a plurality of time instants in the symbol duration. A plurality of tones are allocated to a particular communication device, and a discrete signal is constructed in the time domain by mapping symbols from the constellation to the time instants. A continuous signal is generated by applying an interpolation function to the discrete signal such that the continuous signal only includes sinusoids having frequencies which are equal to the allocated tones.

**69 Claims, 12 Drawing Sheets**

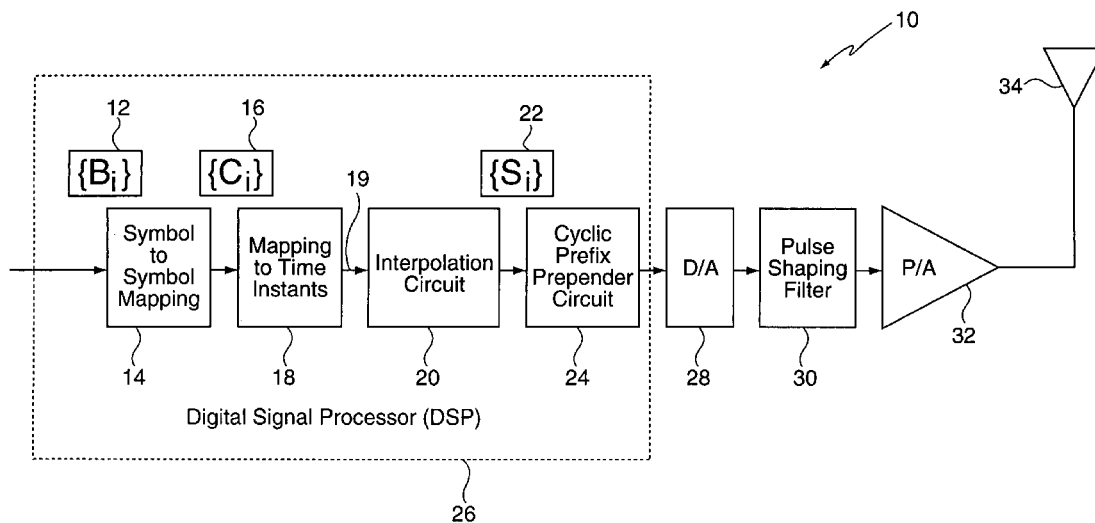

U.S. PATENT DOCUMENTS

6,240,129 B1 5/2001 Reusens et al.  
6,563,881 B1\* 5/2003 Sakoda et al. .... 375/260  
6,657,949 B1\* 12/2003 Jones et al. .... 370/205  
6,674,810 B1\* 1/2004 Cheng ..... 375/260  
6,678,318 B1\* 1/2004 Lai ..... 375/232  
6,717,908 B2 4/2004 Vijayan et al.  
6,850,481 B2\* 2/2005 Wu et al. .... 370/208  
7,010,048 B1 3/2006 Shattil

FOREIGN PATENT DOCUMENTS

EP 0 981 222 A2 2/2000  
EP 1 091 516 A1 4/2001  
WO WO/99/41871 8/1999

OTHER PUBLICATIONS

J. M. Kappes and S. I. Sayegh, "Programmable Demultiplexer/Demodulator Processor", Comsat Laboratories, pp. 230-234.  
Tellado, "Multicarrier Modulation with Low Par", Kluwer Academic, Dordrecht, NL XP-002199500, (2000), pp. 6-11 and 55-60.  
Bahai, Saltzberg, "System Architecture", *Multi-Carrier Digital Communications*, Kluwer Academic, New York, XP-002199501, (1999), pp. 17-21.  
Bingham, "Other Types of MCM", *ADSL, VDSL, and Multicarrier Modulation*, John Wiley & Sons, New York, XP-002199502, (2000), pp. 111-113.  
Carl R. Nassar, Balasubramaniam Natarajan and Steve Shattil, "Introduction of Carrier Interference to Spread Spectrum Multiple Access", Idris Communications, pp. 1-5 (1999) IEEE 0-7803-5554-7/99.

\* cited by examiner

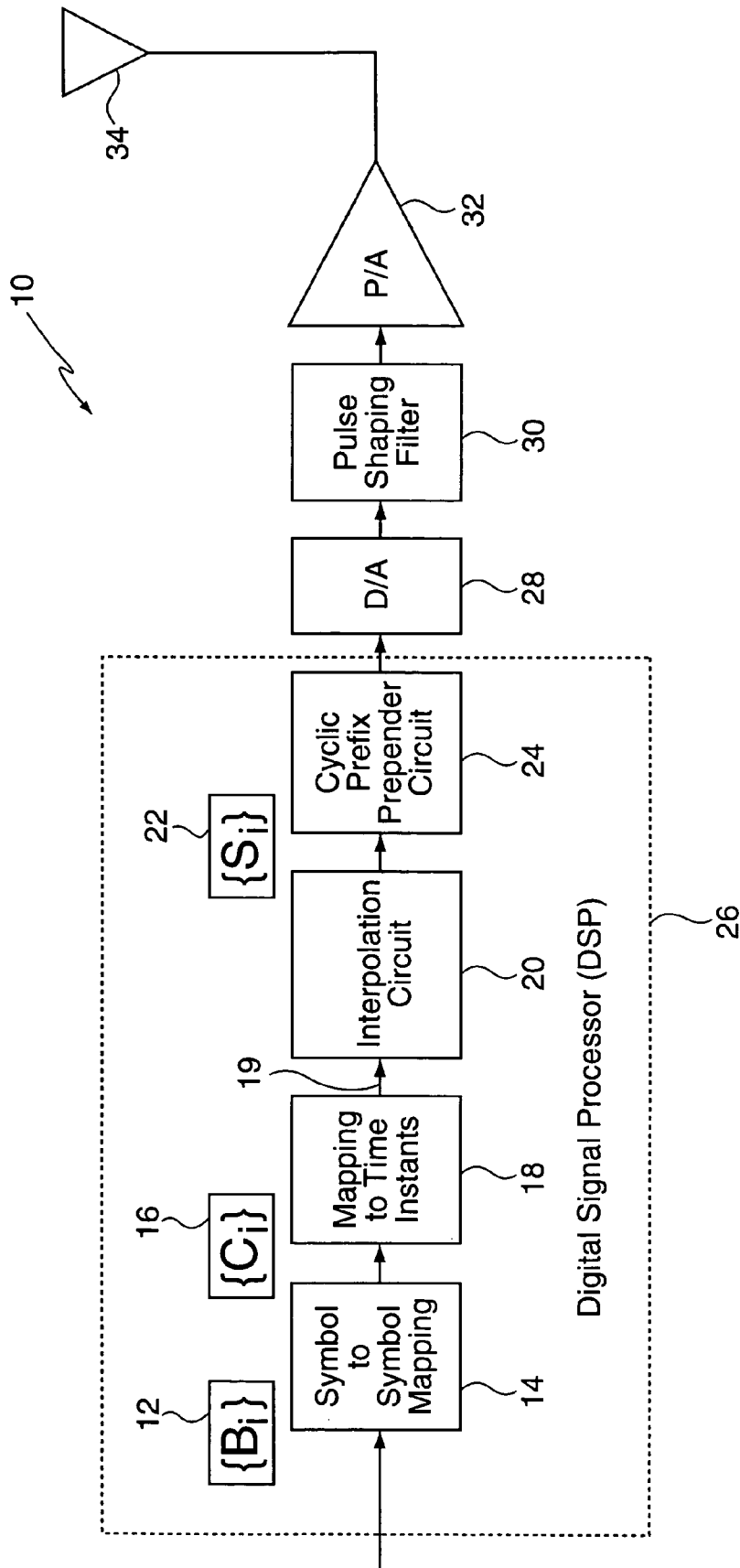

FIG. 1

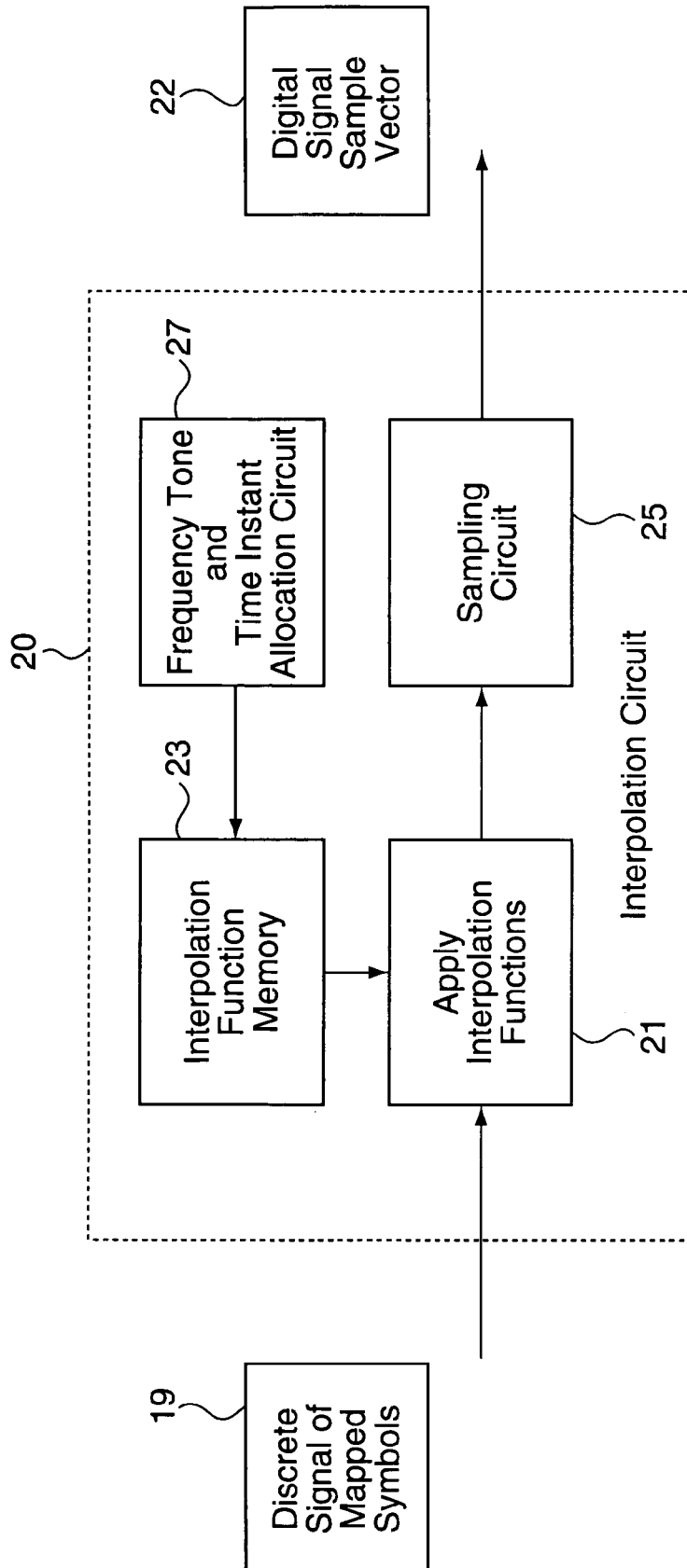

FIG. 2A

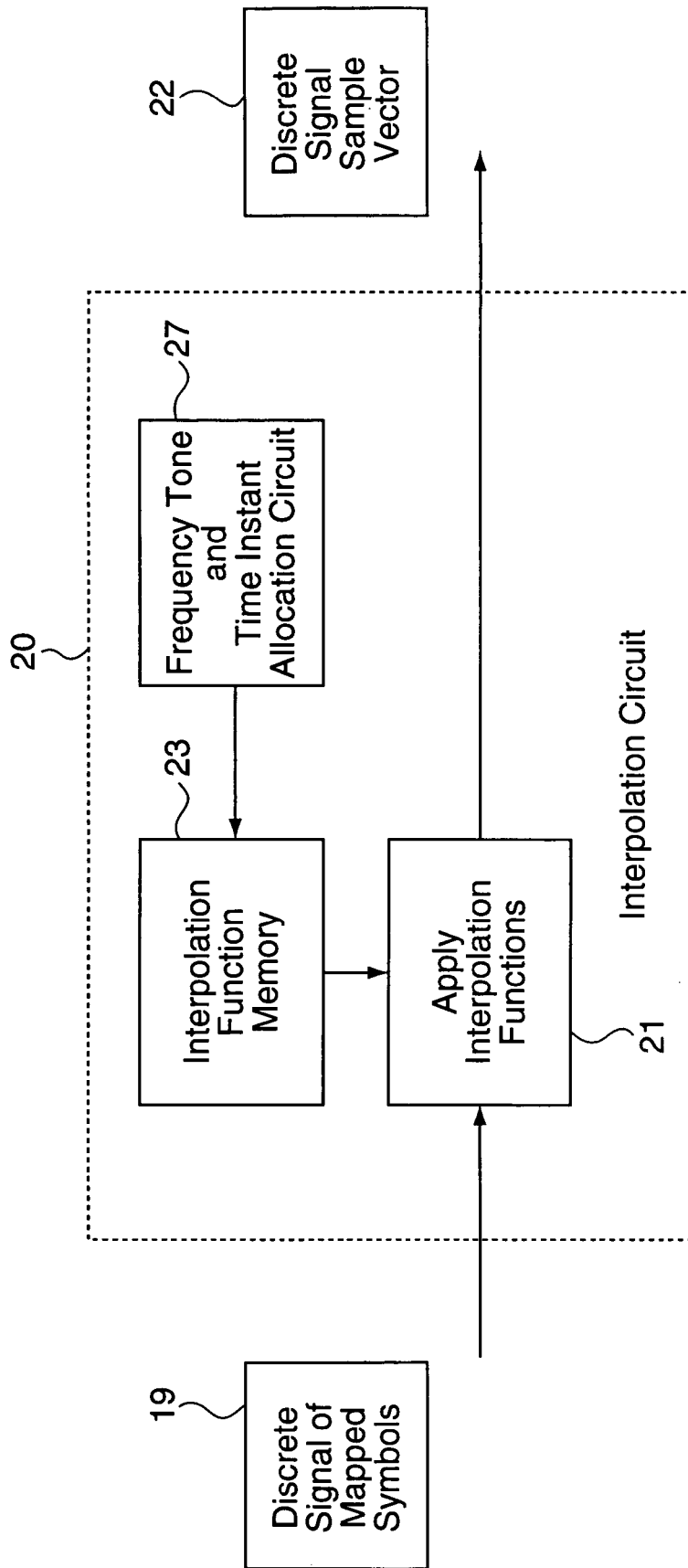

FIG. 2B

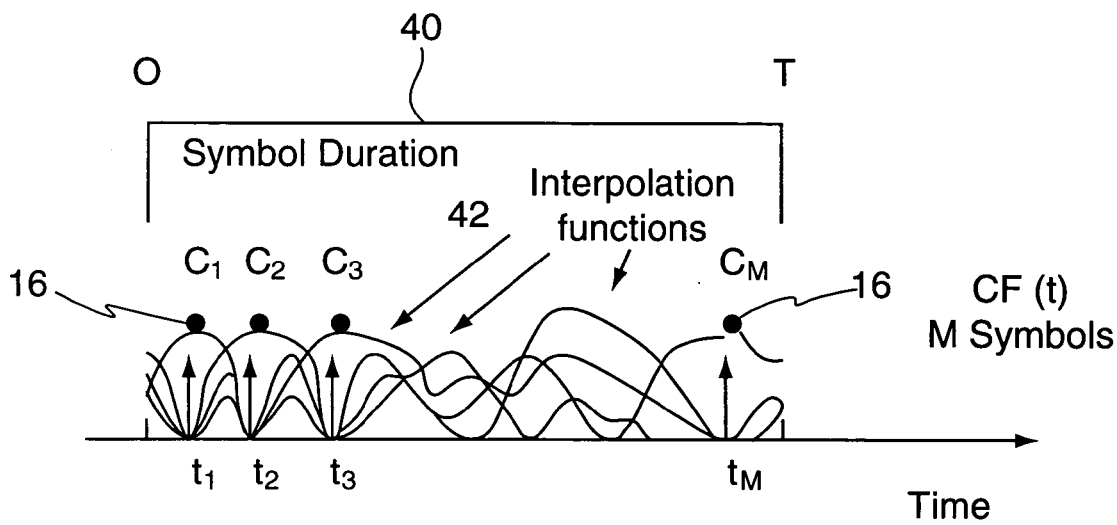

FIG. 3A

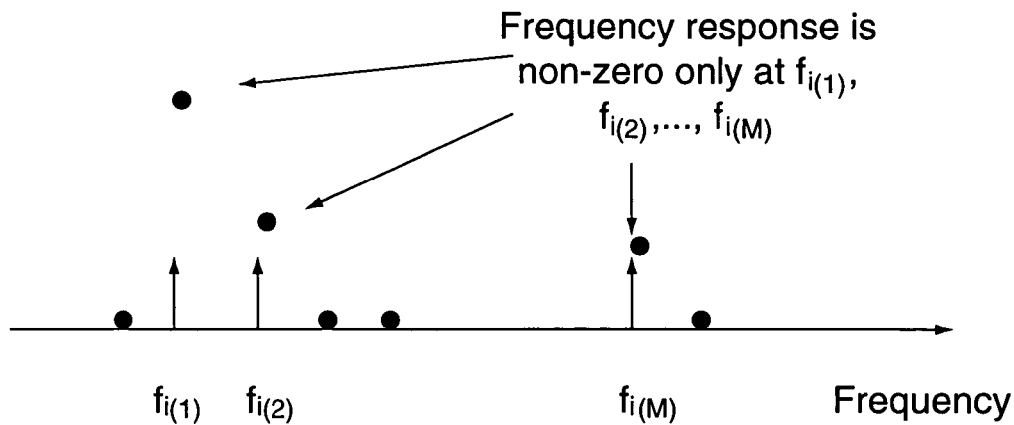

FIG. 3B

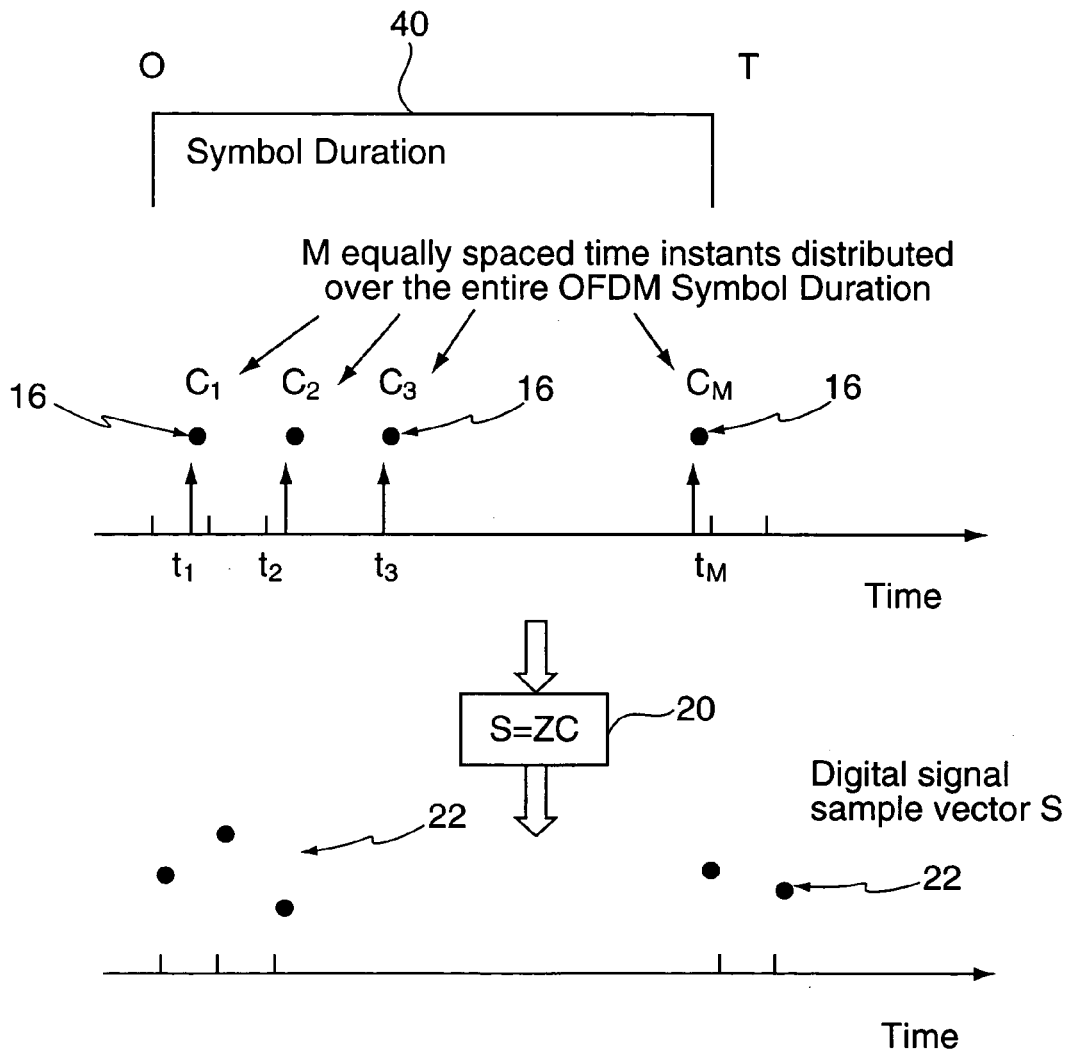

FIG. 4A

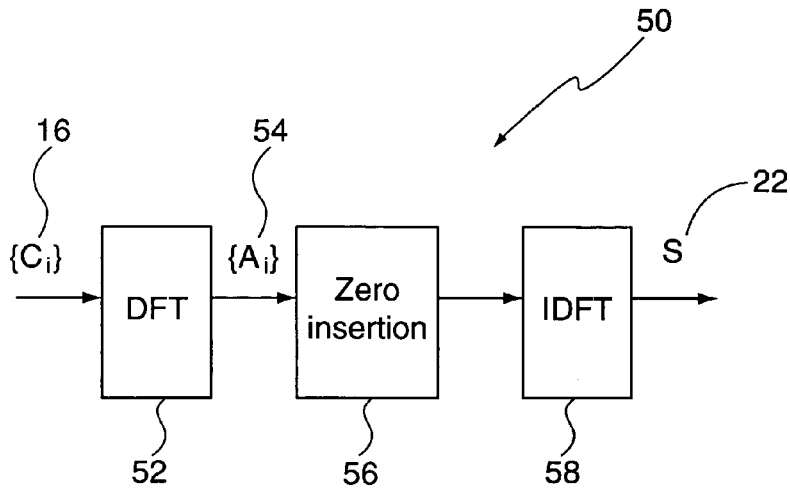

FIG. 4B

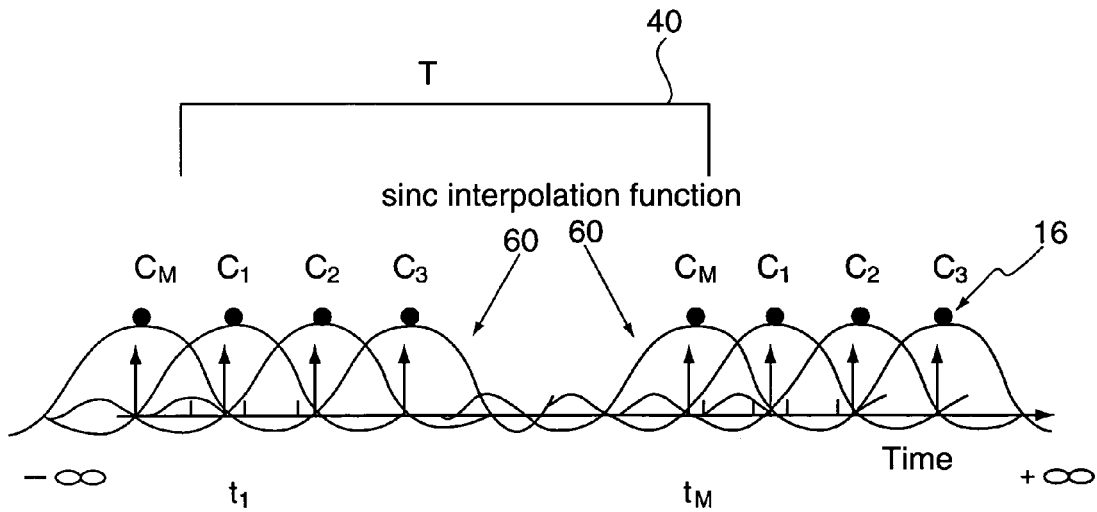

FIG. 4C



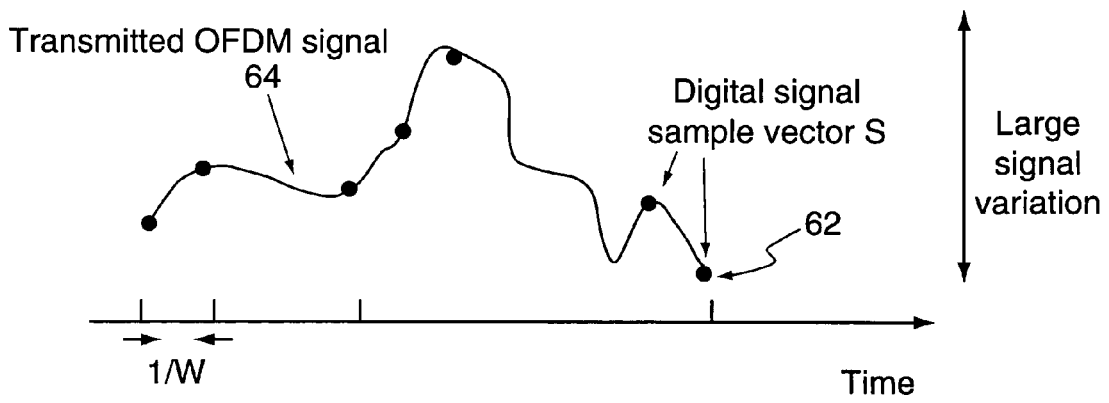

FIG. 4D

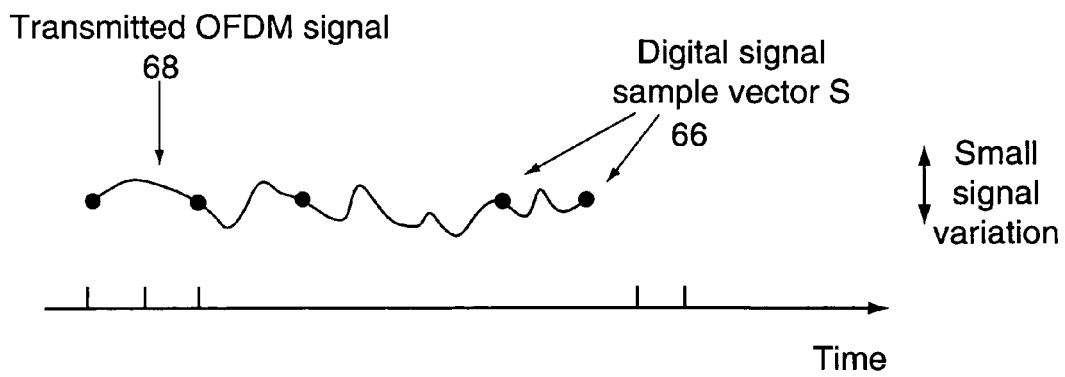

FIG. 4E

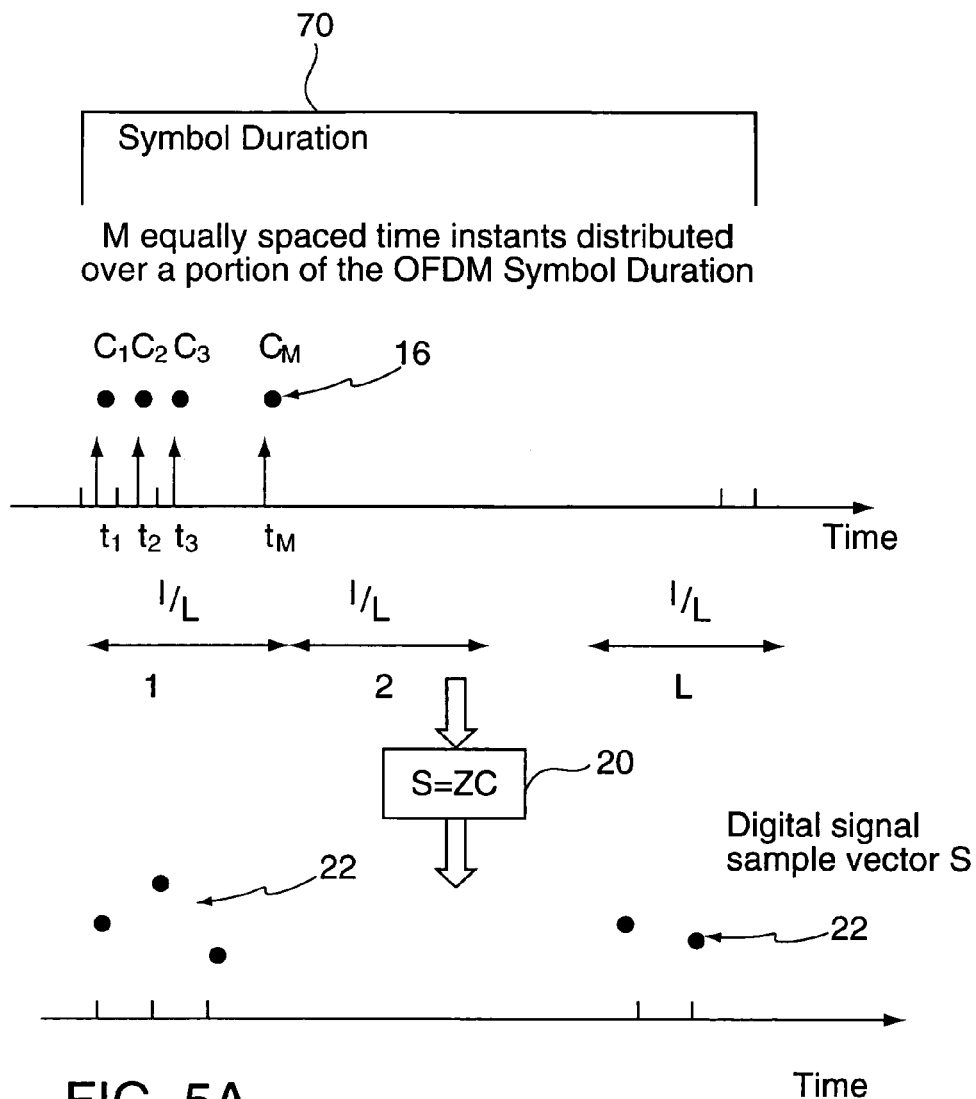

FIG. 5A

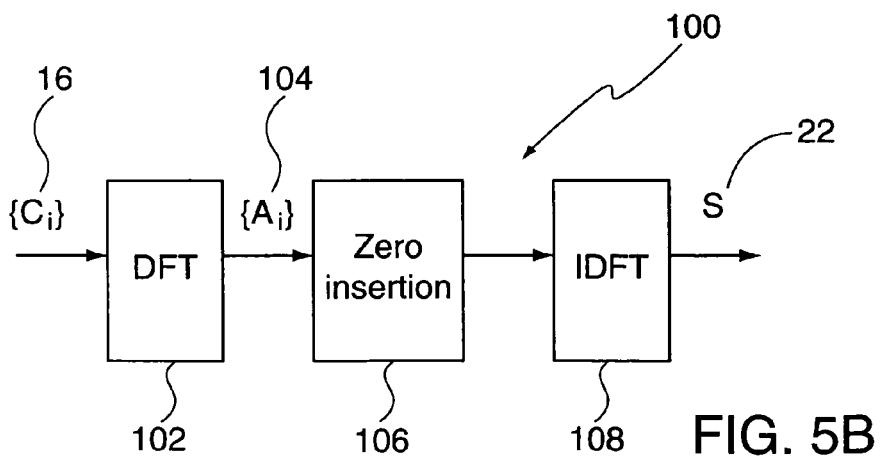

FIG. 5B

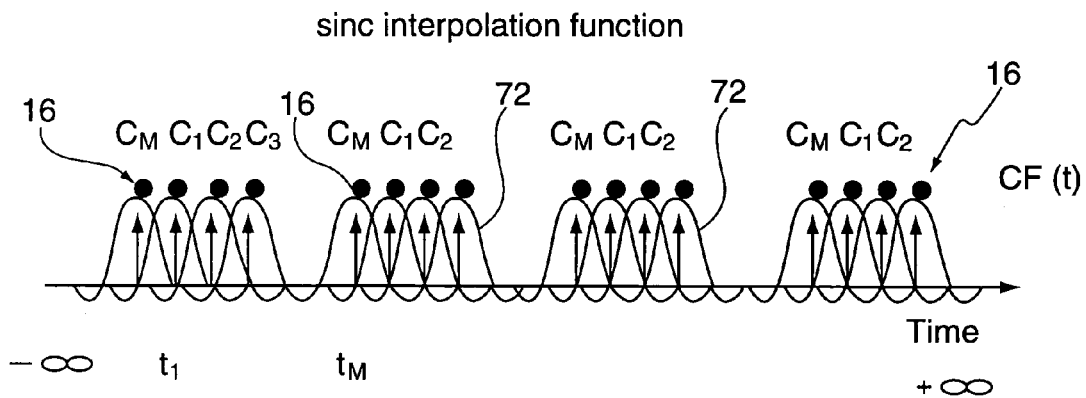

FIG. 5C

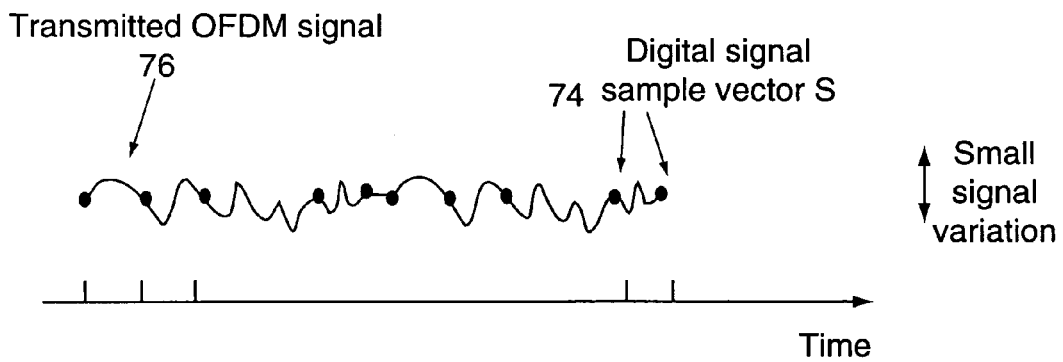

FIG. 5D

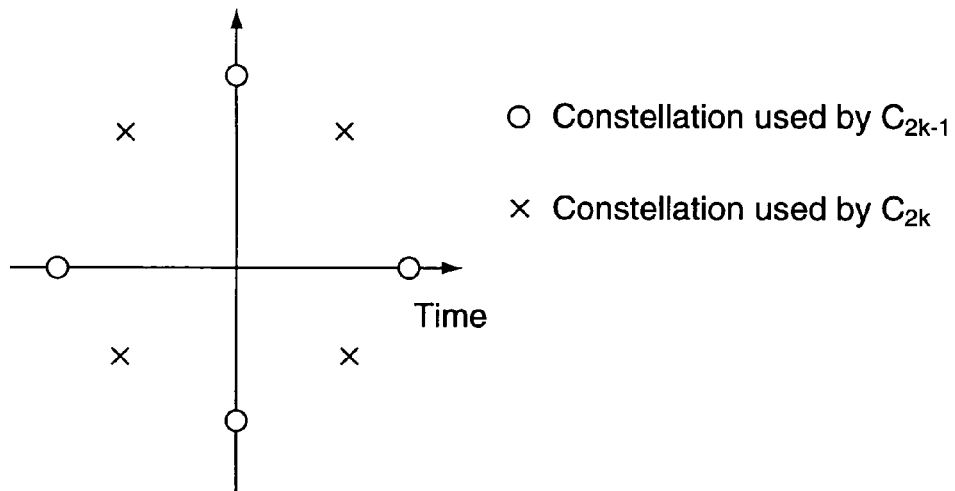

FIG. 6

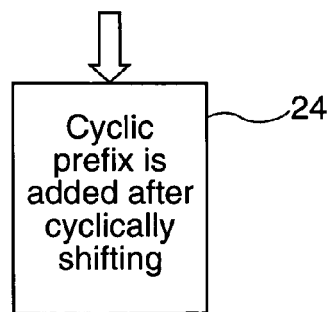
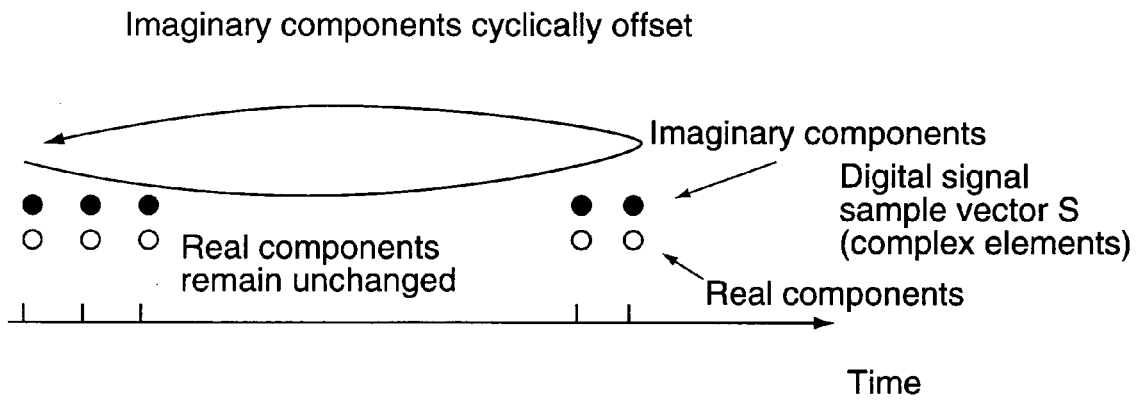

FIG. 7

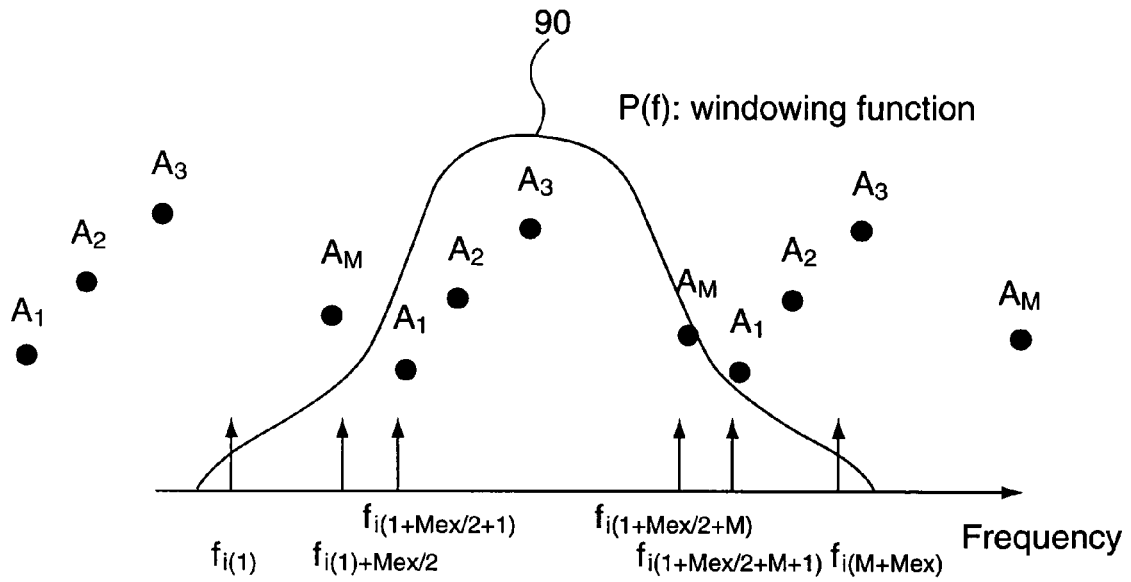

FIG. 8A

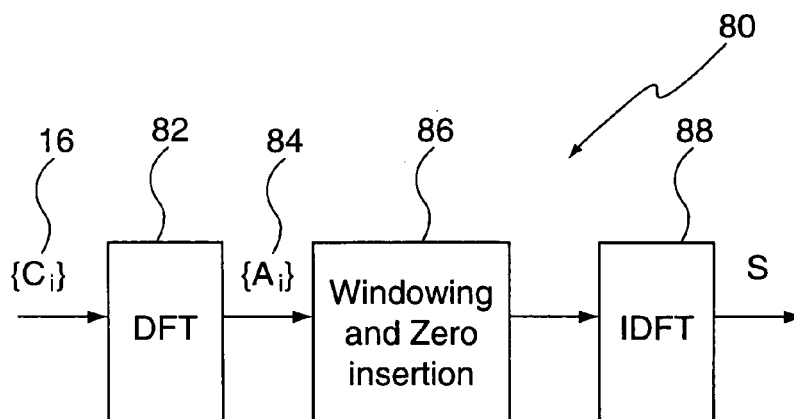

FIG. 8B

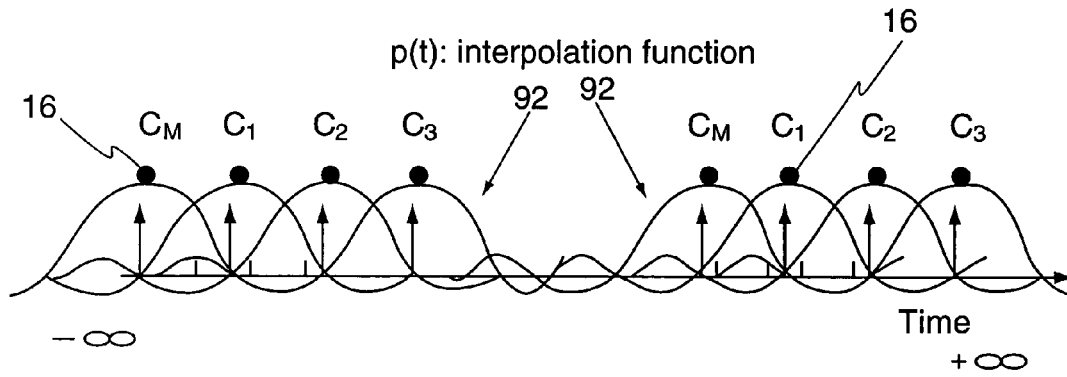

FIG. 8C

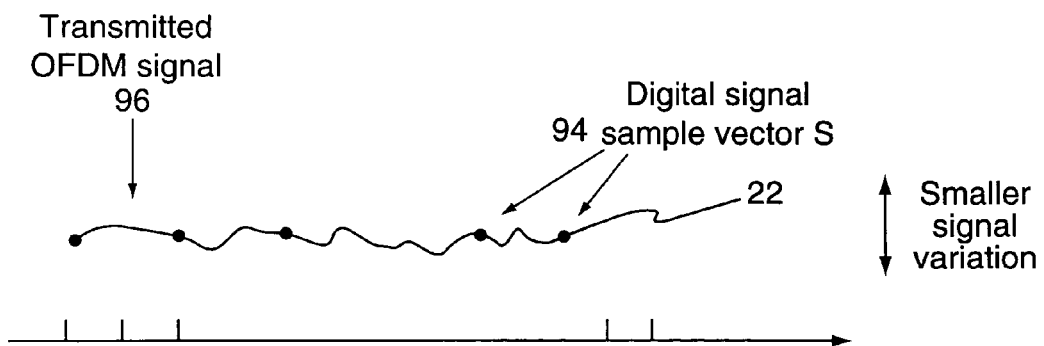

FIG. 8D

## SIGNALING METHOD IN AN OFDM MULTIPLE ACCESS SYSTEM

### CROSS-REFERENCE TO RELATED APPLICATIONS

This application claims priority to U.S. Provisional Application No. 60/230,937, filed on Sep. 13, 2000, and titled "SIGNALING METHOD IN AN OFDM MULTIPLE ACCESS WIRELESS SYSTEM," which is incorporated by reference.

### TECHNICAL FIELD

This invention relates to an orthogonal frequency division multiplexing (OFDM) communication system, and more particularly to an OFDM communication system for a multiple access communication network.

### BACKGROUND

Orthogonal frequency division multiplexing (OFDM) is a relatively well known multiplexing technique for communication systems. OFDM communication systems can be used to provide multiple access communication, where different users are allocated different orthogonal tones within a frequency bandwidth to transmit data at the same time. In an OFDM communication system, the entire bandwidth allocated to the system is divided into orthogonal tones. In particular, for a given symbol duration  $T$  available for user data transmission, and a given bandwidth  $W$ , the number of available orthogonal tones  $F$  is given by  $WT$ . The spacing between the orthogonal tones  $\Delta$  is chosen to be  $1/T$ , thereby making the tones orthogonal. In addition to the symbol duration  $T$  which is available for user data transmission, an additional period of time  $T_c$  can be used for transmission of a cyclic prefix. The cyclic prefix is prepended to each symbol duration  $T$  and is used to compensate for the dispersion introduced by the channel response and by the pulse shaping filter used at the transmitter. Thus, although a total symbol duration of  $T+T_c$  is employed for transmitting an OFDM symbol, only the symbol duration  $T$  is available for user data transmission and is therefore called an OFDM symbol duration.

In prior OFDM techniques, an OFDM signal is first constructed in the frequency domain by mapping symbols of a constellation to prescribed frequency tones. The signal constructed in the frequency domain is then transformed to the time domain by an inverse discrete Fourier transform (IDFT) or inverse fast Fourier transform (IFFT) to obtain the digital signal samples to be transmitted. In general, symbols of the constellation have a relatively low peak-to-average ratio property. For example, symbols of a QPSK constellation all have the same amplitude. However, after being transformed by the IDFT or IFFT, the resultant time domain signal samples are the weighted sum of all the symbols, and therefore generally do not preserve the desirable low peak-to-average ratio property. In particular, the resulting time domain signal typically has a high peak-to-average ratio.

Existing techniques for implementing OFDM communication systems can be highly inefficient due to the relatively high peak-to-average ratio when compared with other signaling schemes, such as single carrier modulation schemes. As a result, existing OFDM techniques are not well suited for a wireless multiple access communication network with highly mobile users because the high peak-to-average ratio of the transmitted signal requires a large amount of power at

the base station and at the wireless device. The large power requirements result in short battery life and more expensive power amplifiers for handheld wireless communication devices or terminals. Accordingly, it is desirable to provide an OFDM technique which reduces the peak-to-average ratio of the signal to be transmitted, while simultaneously taking advantage of the larger communication bandwidth offered by an OFDM communication system.

### SUMMARY

In one aspect of the communication system, power consumption associated with generating and transmitting OFDM signals is reduced as compared to the prior OFDM systems discussed above. The OFDM signaling method includes defining a constellation having a plurality of symbols, defining the symbol duration for the OFDM communication signal, and defining a plurality of time instants in the symbol duration. In a given symbol duration, a plurality of tones in the symbol duration are allocated to a particular transmitter and the signal to be transmitted is represented by a vector of data symbols from the symbol constellation. The symbols are first directly mapped to the prescribed time instants in the symbol duration. A continuous signal is then constructed by applying continuous interpolation functions to the mapped symbols such that the values of the continuous signal at the prescribed time instants are respectively equal to the mapped symbols and the frequency response of the continuous signal only contains sinusoids at the allocated tones. Finally the digital signal, which is to be transmitted, consists of samples of the continuous signal. Alternatively, the digital signal can be generated directly by applying discrete interpolation functions to the mapped symbols. As symbols from the constellation generally have good peak-to-average ratio property, proper choices of allocated frequency tones, prescribed time instants and interpolation functions can result in a minimized peak-to-average ratio of the continuous function and the digital signal samples.

In one implementation the method of directly generating the digital signal samples is to multiply the symbol vector consisting of symbols to be transmitted with a constant matrix, where the constant matrix is determined by the allocated frequency tones and the prescribed time instants. The matrix can be precomputed and stored in a memory.

In one aspect, a transmitter associated with the communication system is allocated a number of contiguous tones and the prescribed time instants are equally-spaced time instants over the entire OFDM symbol duration.

In another aspect, the transmitter is allocated a number of equally-spaced tones and the prescribed time instants are equally-spaced time instants over a fraction of the OFDM symbol duration.

In the above aspects, in addition to the general method, the digital signal samples can be constructed by expanding the mapped symbols to a prescribed set of time instants from minus infinity to plus infinity and interpolating the expanded set of the mapped symbols with a sinc function. Equivalently, the digital signal samples can also be generated by a series of operations including discrete Fourier transformation, zero insertion, and inverse discrete Fourier transformation.

To further reduce the peak-to-average ratio of the digital signal samples obtained through interpolation, when symbols of the constellation are mapped to the prescribed time instants, the constellations used by two adjacent time instants are offset by  $\pi/4$ .

In another aspect of the system, the real and the imaginary components of the resultant digital sample vector are cyclically offset before the cyclic prefix is added. In yet another aspect of the communication system, the intended transmitter is allocated more tones than the number of symbols to be transmitted. Symbols of the constellation are directly mapped to prescribed equally-spaced time instants. The digital signal samples are constructed by expanding the mapped symbols to a prescribed set of time instants from minus infinity to plus infinity and interpolating the expanded set of the mapped symbols with a function whose Fourier transformation satisfies the Nyquist zero intersymbol interference criterion, such as raised cosine functions. The digital signal samples can also be generated by a series of operations including discrete Fourier transformation, windowing, and inverse discrete Fourier transformation.

The details of one or more embodiments of the invention are set forth in the accompanying drawings and the description below. Other features, objects, and advantages of the invention will be apparent from the description and drawings, and from the claims.

#### DESCRIPTION OF DRAWINGS

FIG. 1 is a block diagram of an OFDM system.

FIG. 2A is a block diagram of an interpolation system used by the OFDM system of FIG. 1.

FIG. 2B is a block diagram of another interpolation system used by the OFDM system of FIG. 1.

FIG. 3A is a graph showing symbols mapped to prescribed time instants in the time domain according to the OFDM technique implemented by the system of FIG. 1.

FIG. 3B is a graph showing the frequency domain response of the graph of FIG. 3B.

FIG. 4A shows an implementation technique for producing a digital signal sample vector using time domain symbol mapping in the case where the allocated tones are contiguous.

FIG. 4B is a block diagram showing a communication system for producing a digital signal sample vector in the case where the allocated frequency tones are contiguous.

FIG. 4C is a graph showing the mapping of the symbols to the prescribed time instants, the expansion of the mapped symbols, and the use of a sinc function to interpolate the expanded symbols.

FIG. 4D is a graph showing the large peak-to-average ratio of the resulting digital signal sample vector when the symbols are mapped in the frequency domain in the prior OFDM systems.

FIG. 4E is a graph showing the reduced peak-to-average ratio of the resulting digital signal sample vector when the symbols are mapped in the time domain using the technique of FIGS. 4A-4C.

FIG. 5A shows another implementation technique for producing the digital signal sample vector using time domain symbol mapping in the case where the allocated tones are equally spaced in frequency.

FIG. 5B is a block diagram showing a communication system for producing a digital signal sample vector in the case where the allocated frequency tones are equally spaced.

FIG. 5C is a graph showing the mapping of the symbols to the prescribed time instants, the expansion of the mapped symbols, and the use of a sinc function to interpolate the symbols.

FIG. 5D is a graph showing the reduced peak-to-average ratio of the resulting digital signal sample vector when the symbols are mapped in the time domain using the technique of FIGS. 5A-5C.

FIG. 6 is a graph showing  $\pi/4$  symbol rotation.

FIG. 7 shows the use of a cyclic shift of the real and imaginary signal components.

FIG. 8A is a graph showing application of a windowing function in the frequency domain to further reduce the peak-to-average ratio.

FIG. 8B is a block diagram showing a technique using more tones than the number of symbols to be transmitted for producing a digital signal sample vector.

FIG. 8C is a graph showing the use of an interpolation function corresponding to the window function of FIG. 8B to the symbols mapped to the prescribed time instants.

FIG. 8D is a graph showing the reduced peak-to-average ratio of the resulting digital signal sample vector when the symbols are mapped in the time domain using the technique of FIGS. 8A-8C.

Like reference symbols in the various drawings indicate like elements.

#### DETAILED DESCRIPTION

Referring to FIG. 1, an orthogonal frequency division multiplexing (OFDM) communication system **10** is shown. OFDM communication system **10** receives a first constellation of symbols  $\{B_i\}$  **12** and provides the symbols to a symbol-to-symbol mapping circuit **14**, that produces a second constellation of complex symbols  $\{C_i\}$  **16**. The complex symbols **16** represent data or a stream of data to be transmitted by the OFDM communication system, and may be chosen from a variety of symbol constellations including, but not limited to phase shift keying (PSK) and quadrature amplitude modulation (QAM) symbol constellations. The symbol-to-symbol mapping performed by the mapping circuit **14** is an optional step performed by the OFDM communication system **10**.

Next, a time instant mapping circuit **18** maps each complex symbol **16** to a prescribed time instant within a given OFDM symbol duration. The mapping operation is performed in the time domain such that the mapping circuit **18** generates a discrete signal of mapped symbols within the time domain symbol duration. The output of the mapping circuit **18** is provided to an interpolation circuit **20**, that produces a series of digital signal samples  $\{S_i\}$  **22**. The digital signal samples **22** are formed by sampling a continuous signal, which is constructed by applying one or more predetermined continuous interpolation functions to the mapped complex symbols **19**. Alternatively, the digital signal samples **22** are formed by directly applying one or more predetermined discrete interpolation functions to the mapped complex symbols **19**. When using the technique of applying discrete interpolation functions, no intermediate continuous signal is generated and the step of sampling the continuous signal is not necessary. The operation of the interpolation circuit **20** is described in greater detail below. A cyclic prefix circuit **24** receives the series of digital signal samples **22** from the interpolation circuit **20** and prepends a cyclic prefix to the digital signal samples **22**. The cyclic prefix circuit **24** operates to copy and prepend the last portion of the digital signal sample vector **S** **22** to the beginning of the OFDM symbol duration. The resulting digital signal samples **22** with the prepended cyclic prefix are converted to an analog signal by a digital to analog converter **28**. The resulting analog signal is further pro-



cessed by a pulse shaping filter **30**, the output of which is modulated to a carrier frequency, and amplified by a power amplifier unit **32** for transmission through an antenna **34**.

In one implementation of the OFDM communication system **10**, the symbol-to-symbol mapping circuit **14**, the time instant mapping circuit **18**, the interpolation circuit **20**, and the cyclic prefix circuit **24** are implemented in a digital signal processor (DSP) **26**, and may include a combination of hardware modules and/or software modules. These circuits **14**, **18**, **20**, and **24** can also be implemented as separate discrete circuits within the OFDM communication system **10**.

The details of the interpolation circuit **20** are shown in FIG. **2A**. The interpolation circuit **20** includes an interpolation function module **21** that applies one or more continuous interpolation functions to the discrete signal of mapped symbols **19** to generate a continuous signal in which signal variation between adjacent symbols is minimized. Thus, the continuous signal has a low peak-to-average ratio. The interpolation functions may be precomputed and stored in an interpolation function memory **23** connected to the interpolation function module **21**. A frequency tone and time instant allocation circuit **27** is connected to the interpolation function memory **23** and defines an allocated tone set selected from frequency tones distributed over a predetermined bandwidth associated with the OFDM communication system **10**. The allocated tone set is then provided to the interpolation function memory **23**. The frequency tone and time instant allocation circuit **27** also defines the prescribed time instants distributed over the time domain symbol duration, which can also be stored in the interpolation function memory **23** for use by the interpolation function module **21** as well as other modules within the DSP **26**. The interpolation circuit **20** also includes a sampling circuit **25** for receiving and sampling the continuous signal at discrete time instants distributed over the time domain symbol duration to generate the vector of digital signal samples **22**. Alternatively, in FIG. **2B** the interpolation function module **21** applies one or more discrete interpolation functions to the discrete signal of mapped symbols **19** to directly generate the digital signal sample vector **22**, in which case the sampling circuit **25** (of FIG. **2A**) is not needed. Through applying the discrete interpolation functions, the interpolation function module **21** effectively combines the processing steps of applying the continuous interpolation functions and sampling the intermediate continuous signal.

FIG. **3A** graphically depicts the signal processing steps performed by the various circuits of the DSP **26**. More specifically, FIG. **3A** shows the construction of the signal to be transmitted in a given OFDM time domain symbol duration **40**. The time domain symbol duration **40** is a time interval from 0 to T. For purposes of the following description, the OFDM symbol duration T does not include the cyclic prefix. The signal to be transmitted in the symbol duration **40** is represented by complex symbols  $C_1, C_2, C_3, \dots, C_M$  **16** that are mapped to the prescribed time instants, where M denotes the number of symbols to be transmitted in the symbol duration **40**.

In one implementation, the OFDM communication system **10** is a multiple access communication system where the entire bandwidth available to all transmitters within the system is divided into F orthogonal frequency tones  $f_1, f_2, \dots, f_F$ . In the given symbol duration **40**, a particular transmitter operating within a multiple access communication system is allocated M frequency tones  $f_{i(1)}, f_{i(2)}, \dots, f_{i(M)}$ , which is a subset of  $f_1, f_2, \dots, f_F$ , (the total number of frequency tones) in order to transmit the signal. As part

of this implementation, the number of tones allocated to a particular transmitter is equal to the number of symbols to be transmitted by that transmitter. Later in FIG. **8A**, the number of allocated tones can be greater than the number of symbols to be transmitted. The remaining frequency tones can be used by other transmitters within the communication system. This technique allows OFDM communication system **10** to operate as a multiple access communication system.

The complex data symbols  $C_1, C_2, C_3, \dots, C_M$  **16** are first mapped to  $t_1, t_2, t_3, \dots, t_M$ , respectively, where  $t_1, t_2, t_3, \dots, t_M$  are M prescribed time instants within the time domain symbol duration **40**. The mapping operation generates a discrete signal of mapped symbols. It should be noted that the number of prescribed time instants is equal to the number of symbols M to be transmitted. As described above, the symbol mapping occurs in the time domain. Continuous interpolation functions **42** are then applied to the discrete signal of mapped symbols **16** to generate a continuous function CF(t) for t in the time interval from 0 to T.

The interpolation functions **42** are constructed such that the values of the continuous function CF(t) at time instants  $t_1, t_2, t_3, \dots, t_M$  are respectively equal to  $C_1, C_2, C_3, \dots, C_M$  and the frequency response of the continuous function CF(t) contains only sinusoids at the allocated tones. Therefore, CF(t) is constructed as

$$CF(t) = \sum_{k=1}^M A_k e^{j2\pi f_{i(k)} t}$$

where  $J=\sqrt{-1}$  and coefficients  $A_k$  are given by

$$\begin{bmatrix} A_1 \\ \vdots \\ A_M \end{bmatrix} = \begin{bmatrix} e^{j2\pi f_{i(1)} t_1} & \dots & e^{j2\pi f_{i(M)} t_1} \\ \vdots & & \vdots \\ e^{j2\pi f_{i(1)} t_M} & \dots & e^{j2\pi f_{i(M)} t_M} \end{bmatrix}^{-1} \begin{bmatrix} C_1 \\ \vdots \\ C_M \end{bmatrix}$$

Thus, each coefficient  $A_k$  is generated by multiplying a matrix of predetermined sinusoids with the single column of data symbols  $C_1, C_2, C_3, \dots, C_M$  **16**.

FIG. **3B** shows the frequency response of the continuous function CF(t). More specifically, FIG. **3B** shows that the frequency response of the continuous function is non-zero only at the allocated frequency tones  $f_{i(1)}, f_{i(2)}, \dots, f_{i(M)}$ , and is zero at all other frequency tones.

The output of the DSP **26** is a vector of digital signal samples S **22**, which are the samples of the continuous function CF(t) at discrete time instants 0, T/N, 2T/N, . . . , T(N-1)/N, that is,  $S_1=CF(0), S_2=CF(T/N), S_3=CF(2T/N), \dots, S_N=CF(T(N-1)/N)$ , where N is the number of discrete time instants in the vector of digital signal samples **22**. In a general form,  $t_1, \dots, t_M$  may not necessarily be equal to any of the time instants 0, T/N, 2T/N . . . , T(N-1)/N. Therefore, while the digital signal samples S **22** may occur at the time instants  $t_1, \dots, t_M$ , the OFDM communication system **10** does not require that the time instants 0, TN, 2T . . . , T(N-1)/N be equal to  $t_1, \dots, t_M$ .

In another implementation of OFDM communication system **10**, the digital signal samples S **22** may be generated by the DSP **26** by directly multiplying a matrix of precomputed sinusoidal waveforms Z, operating as discrete inter-

polation functions, with the discrete signal of mapped symbols C in order to satisfy the transformation function  $S=ZC$  according to the following:

$$\begin{aligned}
 S &= \begin{bmatrix} S_1 \\ \vdots \\ S_N \end{bmatrix} = \begin{bmatrix} e^{j2\pi f_{i(1)}^0} & \dots & e^{j2\pi f_{i(M)}^0} \\ \vdots & & \vdots \\ e^{j2\pi f_{i(1)}^{TN-\frac{1}{N}}} & \dots & e^{j2\pi f_{i(M)}^{TN-\frac{1}{N}}} \end{bmatrix} \begin{bmatrix} A_1 \\ \vdots \\ A_M \end{bmatrix} \\
 &= \begin{bmatrix} e^{j2\pi f_{i(1)}^0} & \dots & e^{j2\pi f_{i(M)}^0} \\ \vdots & & \vdots \\ e^{j2\pi f_{i(1)}^{TN-\frac{1}{N}}} & \dots & e^{j2\pi f_{i(M)}^{TN-\frac{1}{N}}} \end{bmatrix} \begin{bmatrix} e^{j2\pi f_{i(1)}^t1} & \dots & e^{j2\pi f_{i(M)}^t1} \\ \vdots & & \vdots \\ e^{j2\pi f_{i(1)}^tM} & \dots & e^{j2\pi f_{i(M)}^tM} \end{bmatrix}^{-1} \begin{bmatrix} C_1 \\ \vdots \\ C_M \end{bmatrix} \\
 &= ZC
 \end{aligned}$$

where C represents the symbol vector, and the matrix Z represents the product of the two matrices in the second line of the above equation. Each column (i) of matrix Z represents the interpolation function **42** of a corresponding symbol  $C_i$  to generate the digital signal samples S **22**. As such, the matrix Z can be pre-computed and stored in the interpolation function memory **23** of the interpolation circuit **20** (FIG. 2B). The interpolation circuit **20** then applies the

Complex symbols  $C_1, \dots, C_M$  **16** are mapped in the time domain to the following time instants  $t_k=(k-1)T/M$ , for  $k=1, \dots, M$ . As part of this implementation, the prescribed

time instants  $t_1, \dots, t_M$  are equally-spaced time instants uniformly distributed over the entire OFDM symbol duration **40** as shown in the first time domain graph of FIG. 4A. Given the choice of the allocated frequency tones and prescribed time instants, the matrix Z, which is used to generate the digital signal samples S as discussed in FIGS. **3A-3B**, can be simplified to

$$Z = \frac{1}{M} \begin{bmatrix} e^{j2\pi f_{i(1)}^0} & \dots & e^{j2\pi f_{i(M)}^0} \\ \vdots & & \vdots \\ e^{j2\pi f_{i(1)}^{TN-\frac{1}{N}}} & \dots & e^{j2\pi f_{i(M)}^{TN-\frac{1}{N}}} \end{bmatrix} \begin{bmatrix} e^{-j2\pi f_{i(1)}^t1} & \dots & e^{-j2\pi f_{i(1)}^tM} \\ \vdots & & \vdots \\ e^{-j2\pi f_{i(M)}^t1} & \dots & e^{-j2\pi f_{i(M)}^tM} \end{bmatrix}$$

discrete interpolation functions **42** defined by the matrix Z to the discrete signal of mapped complex symbols C **16** in order to satisfy the criteria of  $S=ZC$  and to generate the vector of digital signal samples **22**.

The purpose of constructing the signal in the time domain is to directly map the symbols **16**, which have a desirable low peak-to-average ratio property, to the prescribed time instants within the symbol duration **40**. Appropriate interpolation functions **42** are selected to obtain the continuous function CF(t) and the digital signal samples **22** such that the desirable low peak-to-average ratio property of the symbols **16** is substantially preserved for the continuous function and for the digital signal samples **22**. The peak-to-average ratio property of the resulting (interpolated) continuous function CF(t) and the digital signal samples **22** is dependent upon the interpolation functions **42**, the choice of allocated frequency tones  $f_{i(1)}, f_{i(2)}, \dots, f_{i(M)}$  from the set of tones, and the prescribed time instants  $t_1, \dots, t_M$ .

Referring to FIG. 4A, one implementation of the OFDM communication system **10** allocates tones  $f_{i(1)}, f_{i(2)}, \dots, f_{i(M)}$  to the transmitter associated with the communication system that are a subset of contiguous tones in the tone set  $f_1, f_2, \dots, f_F$ . Therefore,  $f_{i(k)}=f_0+(k-1)\Delta$ , for  $k=1, \dots, M$ , where M is the number of symbols. If the OFDM communication system **10** is a multiple access system, each transmitter associated with the communication system is allocated a non-overlapping subset of frequency tones. For purposes of description, let  $f_0=0$ . The construction for the other cases where  $f_0 \neq 0$  can be similarly obtained.

The second time domain graph of FIG. 4A shows the resulting digital signal sample vector S **22** after the interpolation circuit **20** applies the interpolation functions **42** defined by the matrix Z to the complex symbols **16** according to the expression  $S=ZC$ . As part of this implementation, the sampling module **25** is not generally used as the digital signal sample vector S **22** is directly generated from the discrete signal of mapped symbols using the transformation function  $S=ZC$ .

Turning to FIG. 4B, a digital processing system **50** provides another technique for obtaining the vector of digital signal samples S. A DFT circuit **52** receives a discrete signal of complex data symbols  $C_i$  and calculates the frequency responses  $A_1, \dots, A_M$  at tones  $f_{i(1)}, f_{i(2)}, \dots, f_{i(M)}$ , through an M-point discrete Fourier transform (DFT). The vector  $[A_1, \dots, A_M]$  **54** output by the DFT circuit **52** is then expanded to a new vector of length N (the total number of time instants in the discrete signal vector S) by zero insertion at block **56**. More specifically, this process involves putting the  $k^{th}$  symbol  $A_k$  to the  $i(k)^{th}$  element of the new vector, for  $k=1, \dots, M$ , where  $f_{i(k)}$  is the  $k^{th}$  tone allocated to the transmitter, and inserting zeros in all the remaining elements. Finally, an IDFT circuit **58** performs an N-point inverse discrete Fourier transform on the resulting vector (after zero insertion) to obtain the digital signal sample vector S. The collective procedure of DFT, zero insertion and IDFT is one way of implementing the discrete interpolation functions.

Turning to FIG. 4C, another technique for obtaining the digital signal samples S is shown. For simplicity of descrip-

tion, it is assumed that the allocated contiguous tones  $f_{i(1)}, f_{i(2)}, \dots, f_{i(M)}$  are centered at frequency  $\mathbf{0}$ . The construction for the other cases where the allocated tones are not centered at frequency  $\mathbf{0}$  can be similarly obtained. As with FIG. 4A, the prescribed time instants  $t_1, \dots, t_M$  are equally-spaced time instants uniformly distributed over the entire OFDM symbol duration  $\mathbf{40}$ .

The complex symbols  $C_1, \dots, C_M$  are first mapped in the time domain to time instants  $t_1, \dots, t_M$  respectively. Next, the mapped symbols  $C_1, \dots, C_M$  are leftwards and rightwards shifted and replicated to an expanded set of prescribed time instants, which is a superset of  $t_1, \dots, t_M$  and consists of an infinite number of equally-spaced time instants covering the time interval from  $-\infty$  to  $+\infty$ . This technique creates an infinite series of mapped symbols  $C$ . The continuous function  $CF(t)$  is then constructed by interpolating the infinite series of mapped symbols using a sinc interpolation function  $\mathbf{60}$ . Mathematically, the above steps construct the continuous function  $CF(t)$  as

$$CF(t) = \sum_{i=1}^M \left\{ C_i \sum_{k=-\infty}^{\infty} \text{sinc}\left(t - t_i - kT, \frac{T}{M}\right) \right\}$$

where  $\text{sinc}(a,b) = \sin(\pi a/b)/(\pi a/b)$ . The sinc interpolation function  $\mathbf{60}$  can also be precomputed and stored in the interpolation function memory  $\mathbf{23}$ . As discussed in FIG. 3A the digital signal samples  $S$   $\mathbf{22}$  are the samples of the continuous function  $CF(t)$  at time instants  $\mathbf{0}, T/N, \dots, T(N-1)/N$ . In FIGS. 4A-4C, if  $N$  is a multiple of  $M$ , then  $S_{1+(k-1)N/M} = C_k$ , for  $k=1, \dots, M$ . It should be noted that the continuous function  $CF(t)$  only applies to the symbol duration  $\mathbf{40}$  from  $\mathbf{0}$  to  $T$ . The use of time interval from  $-\infty$  to  $+\infty$  is solely for the purpose of mathematically constructing  $CF(t)$ . The discrete interpolation functions, which combine the continuous interpolation functions and the sampling function, can be derived easily from the above description.

For comparison purposes, FIG. 4D illustrates the resulting peak-to-average ratio for a digital signal sample vector  $S$   $\mathbf{62}$  and its associated transmitted OFDM signal  $\mathbf{64}$  produced by symbols  $\mathbf{16}$  where the signal is constructed in the frequency domain. As described above, this known technique of mapping the symbols  $\mathbf{16}$  in the frequency domain produces a large signal variation in the transmitted OFDM signal  $\mathbf{64}$  and results in a large peak-to-average ratio.

FIG. 4E illustrates the resulting small signal variation and low peak-to-average ratio of the digital signal sample vector  $S$   $\mathbf{66}$  associated with the transmitted OFDM signal  $\mathbf{68}$ . As will be appreciated by comparing FIGS. 4D and 4E, mapping the constellation of complex symbols  $\mathbf{16}$  in the time domain produces an OFDM signal  $\mathbf{68}$  having a significantly reduced peak-to-average ratio.

FIG. 5A shows a second implementation of the OFDM communication system  $\mathbf{10}$ , and serves to further generalize the system shown in FIGS. 4A-4C. As part of OFDM system  $\mathbf{10}$ , tones,  $f_{i(1)}, f_{i(2)}, \dots, f_{i(M)}$ , allocated to the transmitter associated with the communication system, are a subset of equally-spaced tones in the tone set  $f_1, f_2, \dots, f_F$ . Therefore,  $f_{i(k)} = f_0 + (k-1)L\Delta$ , for  $k=1, \dots, M$ , and  $L$  is a positive integer number representing the spacing between two adjacent allocated frequency tones. When  $L=1$ , this implementation is equivalent to the implementation technique described in FIGS. 4A-4C. For the sake of description, let  $f_0=0$ . The construction for the other cases where  $f_0 \neq 0$  can be similarly obtained.

In this case where the allocated tones are equally-spaced tones, the constructed continuous function  $CF(t)$  is identical in each of the  $L$  time intervals,  $[0, T/L], [T/L, 2T/L], \dots, [(L-1)T/L, T/L]$ . As part of this technique, symbols  $C_1, \dots, C_M$   $\mathbf{16}$  are mapped to the following time instants  $t_k = (k-1)T/M/L$ , for  $k=1, \dots, M$ . In this implementation, the prescribed time instants  $t_1, \dots, t_M$  are equally-spaced time instants uniformly distributed over a fraction  $(1/L)$  of the symbol duration  $\mathbf{70}$ . As a comparison, in the case of allocated contiguous tones (FIG. 4A), the prescribed time instants are equally-spaced and distributed over the entire symbol duration, as discussed with respect to FIG. 4A.

The procedure for obtaining the digital signal samples  $S$   $\mathbf{22}$  described in FIG. 4A can also be applied with respect to FIG. 5A. More specifically, the digital signal sample vector  $S$  is the product of matrix  $Z$  (defining the discrete interpolation functions) and the symbol vector  $C$ . Given the choice of the allocated frequency tones and prescribed time instants, the matrix  $Z$ , which is used to generate the digital signal samples  $\mathbf{22}$  from the discrete signal of mapped symbols, can be simplified to the same formula as in FIG. 4A with the only change in the definition of  $f_{i(1)}, f_{i(2)}, \dots, f_{i(M)}$  and  $t_1, \dots, t_M$ .

In FIG. 5B, the procedure of obtaining the digital signal sample vector  $S$   $\mathbf{22}$  described in FIG. 4B can also be applied to the case of allocated frequency tones that are equally spaced tones. More specifically, a digital processing system  $\mathbf{100}$  provides another technique for obtaining the vector of digital signal samples  $S$ . A DFT circuit  $\mathbf{102}$  receives a discrete signal of complex data symbols  $C_i$  and calculates the frequency responses  $A_1, \dots, A_M$ , at tones  $f_{i(1)}, f_{i(2)}, \dots, f_{i(M)}$ , through an  $M$ -point discrete Fourier transform (DFT). The vector  $[A_1, \dots, A_M]$   $\mathbf{104}$  output by the DFT circuit  $\mathbf{102}$  is then expanded to a new vector of length  $N$  (the total number of time instants in the digital signal sample vector  $S$ ) by zero insertion at block  $\mathbf{106}$ . More specifically, this process involves putting the  $k^{\text{th}}$  symbol  $A_k$  to the  $i(k)$ th element of the new vector, for  $k=1, \dots, M$ , where  $f_{i(k)}$  is the  $k^{\text{th}}$  tone allocated to the transmitter, and inserting zeros in all the remaining elements. Finally, an IDFT circuit  $\mathbf{108}$  performs an  $N$ -point inverse discrete Fourier transform on the resulting vector (after zero insertion) to obtain the time domain digital signal sample vector  $S$ . The collective procedure of DFT, zero insertion and IDFT is one way of implementing the discrete interpolation functions.

FIG. 5C is the counterpart of FIG. 4C, where symbols  $C_1, \dots, C_M$  are first mapped to  $t_1, \dots, t_M$  respectively over a fraction  $(1/L)$  of the symbol duration  $\mathbf{70}$ . The symbol mapping is also performed in the time domain. Next the mapped symbols  $C_1, \dots, C_M$  are leftwards and rightwards shifted and replicated to an expanded set of prescribed time instants from  $-\infty$  to  $+\infty$  which creates an infinite series of symbols. The continuous function  $CF(t)$  is then constructed by interpolating the infinite series of mapped symbols with a sinc interpolation function  $\mathbf{72}$ . Thus, the continuous function  $CF(t)$  includes the digital signal samples mapped to the prescribed time instants as well as digital sample points between the prescribed time instants. Mathematically, the above steps construct the continuous function as

$$CF(t) = \sum_{i=1}^M \left\{ C_i \sum_{k=-\infty}^{\infty} \text{sinc}\left(t - t_i - kT \frac{1}{L}, \frac{T}{M} \frac{1}{L}\right) \right\}$$

With continued reference to FIG. 5C, each sinc interpolation function 72 is narrower and therefore decays faster than the sinc interpolation function 60 shown in FIG. 4C. The sinc interpolation function 72 can also be precomputed and stored in the interpolation function memory 23 for use by the interpolation function module 21. The digital sample vector S 22 can be obtained in the same technique shown in FIG. 4C. In FIGS. 5A and 5C, if N is a multiple of ML, then  $S_{1+(k-1)N/ML+(j-1)N/L}=C_k$ , for  $k=1, \dots, M$ , and  $j=1, \dots, L$ . The discrete interpolation functions, which combine the continuous interpolation functions and the sampling function, can be derived easily from the above description.

FIG. 5D illustrates the resulting small signal variation and low peak-to-average ratio of the digital signal sample vector S 74 associated with the transmitted OFDM signal 76. As will be appreciated by comparing FIGS. 4D and 5D, mapping the constellation of complex symbols 16 in the time domain produces an OFDM signal 76 having a significantly lower peak-to-average ratio.

Referring now to FIG. 6,  $\pi/4$  symbol rotation technique is used to further reduce the peak-to-average ratio of the transmitted OFDM signal. At an OFDM symbol duration, if symbols  $B_1, \dots, B_M$  of the constellation are to be transmitted, symbols  $B_1, \dots, B_M$  are mapped to another block of complex symbols  $C_1, \dots, C_M$ , where each odd number symbol remains unchanged and each even number symbol is phase rotated by  $\pi/4$ . For example, if symbols  $B_1, \dots, B_M$  belong to a QPSK constellation  $\{0, \pi/2, \pi, \pi3/2\}$ , the odd number symbols  $C_k$  still belong to the same QPSK constellation, while after being phase rotated the even number symbols  $C_k$  belong to another QPSK constellation  $\{\pi/4, \pi3/4, \pi5/4, \pi7/4\}$ . Symbols  $C_1, \dots, C_M$  are then used to construct the digital signal samples 22 in the time domain as described above with respect to FIGS. 3A-5C.

With reference to FIG. 7, another technique for reducing the peak-to-average ratio is shown, which introduces a cyclic offset of the real and imaginary signal components. This technique involves a first step of offsetting the imaginary components of the digital signal samples S 22, which have been generated using the technique of FIGS. 3A-5C, by an integer number of samples. If necessary, the technique then involves a second step of adjusting the timing by a fraction of a sample period between the real and the imaginary signal components in the transmit path.

At an OFDM symbol duration, if the digital signal samples  $S_1, S_2, \dots, S_N$  have been obtained using the method as described in FIGS. 3A-5C, the digital signal sample vector S is then mapped to another vector S' as follows. The real component of digital signal sample  $S'_k$  is equal to that of digital signal sample  $S_k$ . The imaginary component of digital signal sample  $S'_k$  is equal to that of digital signal sample  $S_j$  where index  $j=(k+d-1)\text{mod } N+1$ , for  $k=1, \dots, N$ , with mod representing a module operation. The parameter d is an integer representing the cyclic offset, in terms of number of samples, between the real and imaginary components.

In one implementation, the value of d is determined by

$$\frac{N}{2LM}$$

where L is discussed in FIG. 5A. In one aspect of this technique, d is chosen to be close to

$$\frac{N}{2LM}$$

For example, d can be the integer closest to

$$\frac{N}{2LM}$$

the largest integer not greater than

$$\frac{N}{2LM}$$

or the smallest integer not smaller than

$$\frac{N}{2LM}$$

In one example, d is chosen to be the largest integer not greater than

$$\frac{N}{2LM}$$

This example can be easily extended for other choices of d.

The digital signal sample vector S' is then passed to the cyclic prefix prepender circuit 24, as shown in FIG. 1. Therefore, the operation of half symbol cyclic shifting is carried out before the operation of prepending the cyclic prefix, such as that performed by the cyclic prefix circuit 24 of FIG. 1.

Not specifically shown in FIG. 7, when or after the sample vector S' and the cyclic prefix are outputted to the digital to analog converter 28, the imaginary components are further delayed by an amount of

$$\left(\frac{N}{2LM} - d\right)\frac{T}{N}$$

which is a fraction of a sample period T/N.

As a variation of the technique shown in FIG. 7 (not specifically shown), another technique for achieving a similar result can be used to eliminate the second step of adjusting timing by a fraction of a sample period between the real and the imaginary signal components in the transmit path. As part of this technique, the real and the imaginary components of the desired digital signal samples S 22 are generated separately as described by the following.

13

A first series of digital signal samples **22** are generated using the technique of FIGS. **3A-5C**. The real components of the desired digital signal samples **22** are equal to those of the first series of samples. A second series of digital signal samples **22** are generated using the technique of FIGS. **3A-5C** except for the following changes. The imaginary components of the desired digital signal samples are equal to those of the second series of samples. In the general method described in FIGS. **3, 4A, and 5A**, the matrix

$$\begin{bmatrix} e^{j2\pi f_{i(1)}0} & \dots & e^{j2\pi f_{i(M)}0} \\ \vdots & & \vdots \\ e^{j2\pi f_{i(1)}T\frac{N-1}{N}} & \dots & e^{j2\pi f_{i(M)}T\frac{N-1}{N}} \end{bmatrix}$$

is changed to

$$\begin{bmatrix} e^{j2\pi f_{i(1)}(0-\frac{T}{2LM})} & \dots & e^{j2\pi f_{i(M)}(0-\frac{T}{2LM})} \\ \vdots & & \vdots \\ e^{j2\pi f_{i(1)}(T\frac{N-1}{N}-\frac{T}{2LM})} & \dots & e^{j2\pi f_{i(M)}(T\frac{N-1}{N}-\frac{T}{2LM})} \end{bmatrix}$$

In the block diagram method described with regard to FIG. **4B**, an additional operation is required after zero insertion (block **56**) and before N-point IDFT (block **58**), where each element k in the expanded length N vector is phase rotated by

$$e^{-j2\pi f_k \frac{T}{2LM}}$$

Referring to FIGS. **8A-8D**, another technique for further reducing the peak-to-average ratio is implemented by allocating more frequency tones than the number of complex symbols to be transmitted in a symbol duration **40**. In FIGS. **3-7**, the number of tones allocated to the transmitter associated with the communication system is equal to the number of symbols to be transmitted in a given OFDM symbol duration. Compared with the other techniques described with respect to the previous figures, the technique of FIGS. **8A-8D** requires additional overhead of bandwidth to transmit the same number of complex symbols.

For example, if the communication system **10** is allocated  $M+M_{ex}$  contiguous frequency tones,  $f_{i(1)}, f_{i(2)}, \dots, f_{i(M+M_{ex})}$ , and M symbols  $C_1, \dots, C_M$  of the constellation are to be transmitted at an OFDM symbol duration, from the comparison of FIGS. **4A** and **5A**, the case of allocated contiguous tones can be easily extended to the case of allocated equally-spaced tones. As part of this implementation of the OFDM communication system **10**,  $M_{ex}$  is a positive number representing the number of excess tones to be used and is assumed to be an even number. Therefore, the allocated tone

$$f_{i(k)} = f_0 + \left(k - \frac{M_{ex}}{2} - 1\right)\Delta,$$

14

for  $k=1, \dots, M+M_{ex}$ . For purposes of description, let  $f_0=0$ . The construction for the other cases where  $f_0 \neq 0$  can be similarly obtained.

As with the technique described with respect to FIG. **4A**, the prescribed time instants are  $t_k=(k-1)T/M$ , for  $k=1, \dots, M$ , that is, the prescribed time instants  $t_1, \dots, t_M$  are equally-spaced time instants in the symbol duration **40**.

As part of this technique shown in FIG. **8A**, **P69** is a smooth windowing function **90** in the frequency domain, which is non-zero only over interval  $[f_{i(1)}, f_{i(M+M_{ex})}]$ . In addition,  $P(f)$  **90** also satisfies the Nyquist zero intersymbol interference criterion, i.e.,

$$\sum_{k=-\infty}^{\infty} P(f - kM\Delta) = 1$$

for any frequency f, where  $\Delta$  is the spacing between adjacent tones.

FIG. **8B** shows the block diagram of the technique. As described above, a symbol-to-symbol mapping is optionally performed to generate a discrete signal of mapped complex symbols  $C_1, \dots, C_M$  **16**. The frequency responses  $A_1, \dots, A_M$  **84** are calculated through an M-point discrete Fourier transform (DFT) of the complex symbols **16** at block **82**. At block **86**, vector  $[A_1, \dots, A_M]$  **84** is cyclically expanded to a new vector A' of length N and windowed with a windowing function **90** as follows:

$$A'_k = A_{g(k)} * P((k-1)\Delta + f_1)$$

where index  $g(k)=\text{mod}(k-i(1)-M_{ex}/2, M)+1$ , for  $k=1, \dots, N$ .

At block **88**, the digital signal sample vector S is obtained by taking an N-point inverse discrete Fourier transform (IDFT) of the new vector A'. Finally, the cyclic prefix is added by cyclic prefix circuit **24** as described above with regard to FIG. **1**.

To provide additional insight to the above signal construction technique, assume that the allocated tones  $f_{i(1)}, f_{i(2)}, \dots, f_{i(M+M_{ex})}$  are centered at frequency **0**. In FIG. **8C** (as with FIG. **4C**), symbols  $C_1, \dots, C_M$  are first mapped to equally-spaced time instants in the symbol duration **40**, and are then leftwards and rightwards shifted and replicated from  $-\infty$  to  $+\infty$ . What is different from FIG. **4C** is that a different interpolation function **92**, which is determined by the windowing function **90**, is used to generate the continuous function,

$$CF(t) = \sum_{i=1}^M C_i \sum_{k=-\infty}^{\infty} p(t-t_i-kT)$$

where  $p(t)$  **92** is the time domain response of  $P(f)$  **90**. As with FIG. **4C**, the digital signal samples are obtained by letting  $t=0, T/N, \dots, T(N-1)/N$ .

In one exemplary aspect of this technique, if a raised cosine windowing function is used, i.e.,

$$P(f) = \begin{cases} \frac{T}{M} & \text{if } |f| < (1-\beta)\frac{M}{2T} \\ \frac{T}{2M} \left\{ 1 + \cos \left[ \frac{\pi T}{\beta M} \left( |f| - \frac{(1-\beta)M}{2T} \right) \right] \right\} & \text{if } (1-\beta)\frac{M}{2T} \leq |f| \leq (1+\beta)\frac{M}{2T} \\ 0 & \text{if } |f| > (1+\beta)\frac{M}{2T} \end{cases}$$

10

where  $\beta=(M_{ex}+2)/M$  represents the percentage of excess tone overhead, then, the interpolation function  $p(t)$  **92** is given by

$$p(t) = \frac{\sin(\pi t M / T)}{\pi t M / T} \frac{\cos(\pi \beta t M / T)}{1 - 4\beta^2 t^2 M^2 / T^2}.$$

As  $\beta$  increases, the interpolation function  $p(t)$  **92** decays faster, thereby reducing the probability of having large peak at samples between  $t_r$ .

FIG. **8D** shows the resulting small signal variation and low peak-to-average ratio of the digital signal sample vector **S 94** associated with the transmitted OFDM signal **96**. As will be appreciated, mapping the constellation symbols **16** in the time domain produces an OFDM signal **96** having a significantly lower peak-to-average signal ratio.

A number of embodiments of the invention have been described. Nevertheless, it will be understood that various modifications may be made without departing from the spirit and scope of the invention. Accordingly, other embodiments are within the scope of the following claims.

What is claimed is:

**1.** A communication device for use in a communications system that uses multiple tones distributed over a predetermined bandwidth to communicate data, the device comprising:

a mapping circuit that receives data symbols and maps the symbols to prescribed time instants in a predetermined time interval to generate a discrete signal including mapped symbols, each mapped symbol corresponding to a discrete point in time;

an interpolation circuit that receives the discrete signal and generates a continuous signal by applying an interpolation function to the discrete signal, the interpolation function operating on the discrete signal such that a frequency response of the continuous signal includes sinusoids having non-zero values at a first set of tones, the first set of tones being a subset of said multiple tones, the non-zero value at each of said first set of tones being a function of a plurality of mapped symbols corresponding to different discrete points in time, the frequency response of the continuous signal also including zero values at a second set of tones, the second set of tones being different from said first set of tones and being another subset of said multiple tones; and

a cyclic prefix circuit located after the interpolation circuit to prepend a cyclic prefix.

**2.** The device of claim **1** wherein the discrete time instants are defined within the range of  $0, T/N, 2T/N, \dots, T(N-1)/N$ , where  $N$  is a total number of time instants in the predetermined time interval.

**3.** The device of claim **1** wherein the frequency tones within the first set of tones are contiguous frequency tones,

and the prescribed time instants are equally spaced and uniformly distributed over one symbol duration.

**4.** The device of claim **1** wherein the frequency tones within the first set of tones are equally spaced frequency tones, and the prescribed time instants are equally spaced and uniformly distributed over a fraction of one symbol duration.

**5.** The device of claim **4** wherein a fraction of one symbol duration is defined by  $1/L$  where  $L$  is the spacing between two adjacent tones in the first set of tones.

**6.** The device of claim **1** wherein a total number of discrete time instants is greater than or equal to a total number of frequency tones distributed over the predetermined bandwidth.

**7.** The device of claim **1** wherein the interpolation circuit further includes a memory for storing the predetermined interpolation functions, and an interpolation function module for retrieving the interpolation functions from the memory and applying the interpolation functions to the discrete signal to generate the continuous signal.

**8.** The device of claim **7** wherein the interpolation functions comprise a matrix of precomputed sinusoidal waveforms.

**9.** The device of claim **7** wherein the interpolation functions comprise continuous interpolation functions.

**10.** The device of claim **1** wherein the mapping circuit replicates the discrete signal of mapped symbols to generate an infinite series of mapped symbols over prescribed time instants covering a time interval from  $-\infty$  to  $+\infty$ .

**11.** The device of claim **10** wherein the interpolation functions comprise sinc interpolation functions, and the interpolation circuit applies the sinc interpolation functions to the infinite series of mapped symbols.

**12.** The device of claim **1** wherein the data symbols are complex symbols associated with a symbol constellation.

**13.** The device of claim **1** further including a digital signal processor for implementing the mapping circuit and the interpolation circuit.

**14.** The device of claim **1** wherein said interpolation circuit includes a sampling circuit for sampling the continuous signal to produce a digital signal sample vector; and

wherein the cyclic prefix circuit receives the digital signal sample vector from the sampling circuit and prepends the cyclic prefix to the digital signal sample vector.

**15.** The device of claim **14** wherein the cyclic prefix circuit operates to copy an end portion of the digital signal sample vector and prepend the end portion to a beginning portion of the digital signal sample vector.

**16.** The device of claim **1**, wherein said interpolation circuit includes a sampling circuit for sampling the continuous signal to produce a digital signal sample vector, the device further including a digital to analog converter operable to receive the digital signal sample vector and generate an analog signal for transmission.

17

17. A communication system for generating an OFDM signal having allocated frequency tones distributed over a predetermined bandwidth, the communication system comprising:

- a mapping module that receives data symbols from a symbol constellation and maps the symbols to prescribed time instants in a time domain symbol duration to generate a discrete signal of mapped symbols;
- an interpolation module that receives the discrete signal and generates a continuous signal by applying an interpolation function to the discrete signal;
- wherein the interpolation function operates on the discrete signal such that a frequency response of the continuous signal includes sinusoids having non-zero values at the allocated frequency tones, and zero values at frequency tones other than the allocated frequency tones; and
- a cyclic prefix circuit located after the interpolation module to prepend a cyclic prefix.

18. The communication system of claim 17 wherein the allocated frequency tones are associated with a designated transmitter within the communication system.

19. The communication system of claim 17 wherein the allocated frequency tones are contiguous frequency zones, and the prescribed time instants are equally spaced time instants uniformly distributed over one symbol duration.

20. The communication system of claim 17 wherein the allocated frequency tones are equally spaced frequency tones, and the prescribed time instants are equally spaced time instants uniformly distributed over a fraction of one symbol duration.

21. The communication system of claim 20 wherein a fraction of one symbol duration is defined by  $1/L$  where  $L$  is the spacing between two adjacent allocated frequency tones.

22. The communication system of claim 17 wherein the interpolation function operates on the discrete signal such that values of the continuous signal at the prescribed time instants are equal to the mapped symbols.

23. The communication system of claim 17 wherein the interpolation module includes a memory for storing the interpolation function, the interpolation module retrieving the interpolation function from the memory and applying the interpolation function to the discrete signal to generate the continuous signal.

24. The communication system of claim 23 wherein the interpolation function comprises a sine interpolation function.

25. A communication system for generating an OFDM signal having allocated frequency tones distributed over a predetermined bandwidth, the communication system comprising:

- a mapping module that receives data symbols from a symbol constellation and maps the symbols to prescribed time instants in a time domain symbol duration to generate a discrete signal of mapped symbols; and
- an interpolation module that receives the discrete signal and generates a digital signal sample vector by applying an interpolation function to the discrete signal;
- wherein the interpolation function operates on the discrete signal such that a frequency response of the digital signal sample vector includes sinusoids having non-zero values at the allocated frequency tones, and zero values at frequency tones other than the allocated frequency tones; and
- a cyclic prefix module located after the interpolation module for prepending a cyclic prefix.

26. The communication system of claim 25 wherein the interpolation module further includes a memory for storing

18

the interpolation function, the interpolation module retrieving the interpolation function from the memory and applying the interpolation function to the discrete signal to generate a digital signal sample vector.

27. The communication system of claim 26 wherein the interpolation function is a discrete interpolation function comprising a matrix of precomputed sinusoidal waveforms.

28. The communication system of claim 27 wherein the interpolation module multiplies the matrix of precomputed sinusoidal waveforms with the discrete signal of mapped symbols over the time domain symbol duration to generate the digital signal sample vector.

29. A communication system for generating an OFDM signal having allocated frequency tones distributed over a predetermined bandwidth, the communication system comprising:

- a mapping module that receives data symbols from a symbol constellation and maps the symbols to prescribed time instants in a time domain symbol duration to generate a discrete signal of mapped symbols; and
- an interpolation module that receives the discrete signal and generates a continuous signal by applying an interpolation function to the discrete signal;
- wherein the interpolation function operates on the discrete signal such that values of the continuous signal at the prescribed time instants are equal to the mapped symbols; and
- a cyclic prefix module located after the interpolation module to prepend a cyclic prefix.

30. A communication system comprising:

- a mapping circuit that receives data symbols and maps the symbols to prescribed time instants in a time domain symbol duration to generate a discrete signal of mapped symbols; and
- an interpolation circuit that receives the discrete signal and generates a continuous signal by applying an interpolation function that operates on the discrete signal such that a frequency response of the continuous signal includes sinusoids having non-zero values at a first set of tones, and zero values at a second set of tones; and
- a cyclic prefix module located after the interpolation circuit to prepend a cyclic prefix.

31. The communication system of claim 30 wherein the continuous signal comprises an OFDM communication signal and wherein the value of the continuous signal at each of the prescribed time instants is a function of the mapped symbol at said prescribed time instant.

32. The communication system of claim 30 wherein the first set of tones are allocated to one communication device within the communication system.

33. The communication system of claim 32 wherein the communication device comprises a transmitter.

34. The communication system of claim 30 wherein the interpolation circuit is adapted to store the interpolation function.

35. The communication system of claim 34 wherein the interpolation function is a sine interpolation function.

36. The communication system of claim 34 wherein the interpolation function is a matrix of precomputed sinusoidal waveforms.

37. The communication system of claim 36 wherein the interpolation circuit multiplies the matrix of precomputed sinusoidal waveforms with the discrete signal of mapped symbols over the time domain symbol duration to generate the continuous signal.

**38.** The communication system of claim **30** further comprising a sampling circuit that samples the continuous signal at discrete time instants distributed over the time domain symbol duration to generate a digital signal sample vector.

**39.** The communication system of claim **38** wherein the discrete time instants are defined within the range of  $0, T/N, 2T/N, \dots, T(N-1)/N$ , where  $N$  is a total number of time instants in the time domain symbol duration.

**40.** The communication system of claim **30** wherein the data symbols are complex symbols associated with a symbol constellation.

**41.** A communication system comprising:

a mapping circuit that receives data symbols and maps the symbols to prescribed time instants in a time domain symbol duration to generate a discrete signal of mapped symbols; and

an interpolation circuit that receives the discrete signal and generates a digital signal sample Vector by applying an interpolation function that operates on the discrete signal such that a frequency response of the digital signal sample vector includes sinusoids having non-zero values at a first set of tones, and zero values at a second set of tones; and

a cyclic prefix circuit located after the interpolation module to prepend a cyclic prefix.

**42.** The communication system of claim **41** wherein the interpolation circuit is adapted to store the interpolation function.

**43.** The communication system of claim **42** wherein the interpolation function is a matrix of precomputed sinusoidal waveforms.

**44.** The communication system of claim **43** wherein the interpolation circuit multiplies the matrix of precomputed sinusoidal waveforms with the discrete signal a of mapped symbols over the time domain symbol duration to generate the digital signal sample vector.

**45.** A method for reducing a peak-to-average ratio in an OFDM communication signal transmitted by a communication device, the method comprising:

providing a time domain symbol duration having equally spaced time instants;

allocating a predetermined number of frequency tones to the communication device;

receiving as input data symbols to be transmitted by the OFDM communication signal;

mapping the data symbols to the equally spaced time instants in the symbol duration to generate a discrete signal of mapped symbols;

generating a continuous signal by applying an interpolation function to the discrete signal, the interpolation function operating on the discrete signal such that a frequency response of the continuous signal includes sinusoids having non-zero values at the allocated frequency tones, and zero values at frequency tones other than the allocated frequency tones; and

sampling the continuous signal at discrete time instants distributed over the time domain symbol duration, to generate a digital signal sample vector; and

prepending a cyclic prefix to the digital signal sample vector produced by sampling the continuous signal after generation of the continuous signal by applying the interpolation function.

**46.** The method of claim **45** wherein the discrete time instants are defined within the range of  $0, T/N, 2T/N, \dots, T(N-1)/N$ , where  $N$  is a total number of time instants in the symbol duration.

**47.** The method of claim **45** wherein the step of allocating a predetermined number of frequency tones to the communication device further comprises allocating contiguous frequency tones to the communication device.

**48.** The method of claim **45** wherein the step of allocating a predetermined number of frequency tones to the communication device further comprises allocating equally spaced frequency tones to the communication device.

**49.** The method of claim **45** further including the step of replicating the mapped symbols within the symbol duration to generate an infinite series of data symbols over equally spaced time instants covering a time interval from  $-\infty$  to  $+\infty$  after the step of mapping the data symbols.

**50.** The method of claim **49** wherein the step of generating the continuous signal further comprises applying a sinc interpolation function to the infinite series of data symbols.

**51.** The method of claim **45** wherein the discrete signal of mapped symbols includes odd numbered symbols and even number symbols, and further comprises the step of phase rotating each even numbered symbol by  $\pi/4$ .

**52.** The method of claim **45** further comprising the step of mapping the data symbols to a block of complex data symbols wherein the block of complex data symbols includes odd numbered symbols and even numbered symbols;

phase rotating each even numbered symbol by  $\pi/4$ ; and mapping the block of complex data symbols to equally spaced time instants in the symbol duration to generate the discrete signal of mapped symbols.

**53.** The method of claim **45** further comprising the step of offsetting imaginary components of the digital signal sample vector by a predetermined number of samples for producing a cyclic offset in the digital signal sample vector.

**54.** The method of claim **53** further comprising the step of fixing a position of real components of the digital signal sample vector with respect to the imaginary components.

**55.** The method of claim **53** wherein the predetermined number of samples is an integer number of samples.

**56.** The method of claim **53** wherein the predetermined number of samples is a fraction of one sample period.

**57.** The method of claim **45** further comprising the step of prepending a cyclic prefix to the digital signal sample vector.

**58.** The method of claim **57** wherein the step of prepending a cyclic prefix further comprises copying an end portion of the digital signal sample vector and prepending the end portion to a beginning portion of the digital signal sample vector.

**59.** The method of claim **45** wherein the step of allocating a predetermined number of frequency tones includes allocating more tones than a total number of data symbols to be transmitted in the symbol duration.

**60.** The method of claim **45** wherein the interpolation function is a raised cosine function.

**61.** The method of claim **45** further comprising the step of precomputing the interpolation function and storing the interpolation function in a memory.

**62.** A method for reducing a peak-to-average ratio in an OFDM communication signal having a set of tones distributed over a predetermined bandwidth, the method comprising:

defining a symbol duration for the OFDM communication signal;

defining time instants in the symbol duration;

allocating frequency tones from the set of tones to a particular communication device;



21

receiving as input data symbols from a symbol constellation, the data symbols being transmitted by the OFDM communication signal;  
 mapping the data symbols to the time instants to generate a discrete signal in the time domain;  
 generating a digital signal sample vector by applying interpolation functions to the discrete signal such that a frequency response of the digital signal sample vector includes sinusoids having non-zero values at allocated frequency tones, and zero values at frequency tones other than the allocated frequency tones;  
 prepending a cyclic prefix to the digital signal sample vector after the digital signal sample vector is generated by applying the interpolation function.

63. The method of claim 62 wherein the step of allocating frequency tones further includes allocating contiguous tones, and mapping the data symbols to equally spaced time instants distributed over one symbol duration.

64. The method of claim 62 wherein the step of allocating frequency tones further includes allocating equally spaced tones, and mapping the data symbols to equally spaced time instants distributed over a portion of one symbol duration.

65. The method of claim 62 wherein the data symbols are complex symbols.

66. The method of claim 62 wherein the discrete signal includes odd numbered symbols and even number symbols, and further comprises the step of phase rotating each even numbered symbol by  $\pi/4$ .

67. The method of claim 62 further comprising the step of mapping the data symbols to a block of complex data symbols wherein the block of complex data symbols includes odd numbered symbols and even numbered symbols;  
 phase rotating each even numbered symbol by  $\pi/4$ ; and  
 mapping the block of complex data symbols to equally spaced time instants in the symbol duration to generate the discrete signal.

22

68. The method of claim 62 further comprising the step of offsetting imaginary components of the digital signal sample vector by a predetermined number of samples for producing a cyclic offset in the digital signal sample vector.

69. A communication device for use in a communications system that uses multiple tones distributed over a predetermined bandwidth to communicate data, the device comprising:

a mapping circuit that receives data symbols and maps the symbols to prescribed time instants in a predetermined time interval to generate a discrete signal including mapped symbols, each mapped symbol corresponding to a discrete point in time, each discrete point in time to which a symbol is mapped not overlapping a discrete point in time to which another symbol is mapped, multiple symbols being mapped to said predetermined time interval, discrete points in time to which symbols are mapped having a predetermined spacing;

an interpolation circuit that receives the discrete signal and generates a continuous signal by applying an interpolation function to the discrete signal, the interpolation function operating on the discrete signal such that a frequency response of the continuous signal includes sinusoids having non-zero values at a first set of tones, the first set of tones being a subset of said multiple tones, the non-zero value at each of said first set of tones being a function of a plurality of mapped symbols corresponding to different discrete points in time, the frequency response of the continuous signal also including zero values at a second set of tones, the second set of tones being different from said first set of tones and being another subset of said multiple tones; and

a cyclic prefix circuit located after the interpolation circuit for prepending a cyclic prefix.

\* \* \* \* \*